

Part No.: RS2W200460-2.4

Power divider /Combiner 2 Way 2.4 50Ω 20 to 46 GHz

电气特性 Electrical:

工作频率 Frequency Range: 20-46 GHz
 插入损耗 Insertion Loss: $\leq 1.8\text{dB}$
 驻波 VSWR: $\leq 1.8 : 1$
 隔离 Isolation: $\geq 15\text{dB}$
 幅度平衡 Amplitude Balance: $\leq \pm 0.5\text{dB}$
 相位平衡 Phase Balance: $\leq \pm 5^\circ$
 耐功率 Power Handling: 20 Watt
 方向功率 Reverse Power : 2 Watt
 阻抗 Impedance: 50 OHMS

机械特性 Mechanical :

温度范围 Temperature Range: $-55^\circ\text{C} - +85^\circ\text{C}$
 接口 Connectors: 2.4-Female
 相对湿度 Relative Humidity: 0 ~ 90%

外形尺寸 Outline Drawing:

Unit: mm

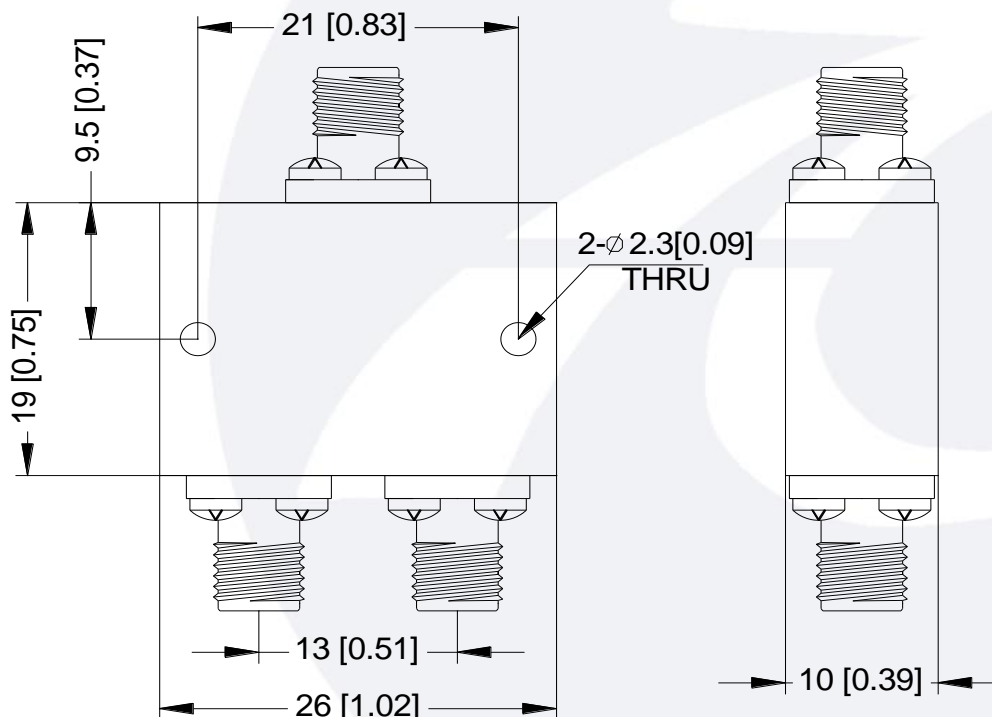



Trc1 **S11** SWR 200 mU/ Ref 1 U Cal 1

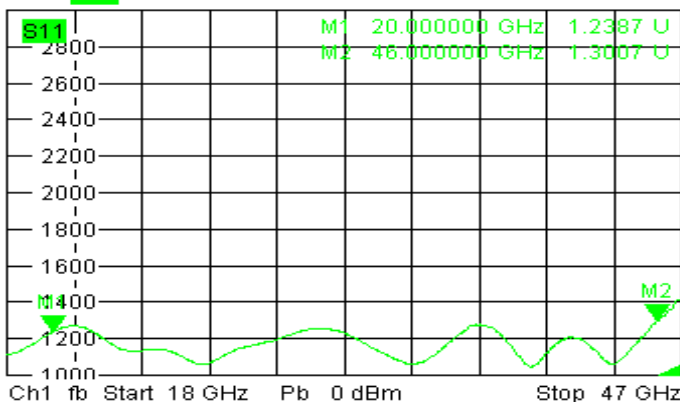

Trc2 **S12** Phase 5° / Ref 0° Cal Math 2
Mem5[Trc2] **S12** Phase 5° / Ref 0° Invisible

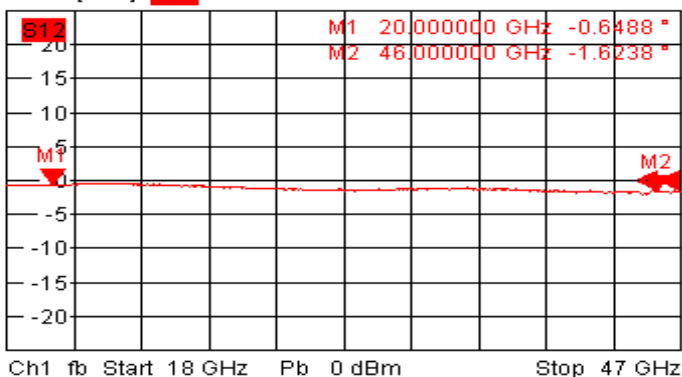

Trc3 **S21** dB Mag 1.3 dB / Ref -3 dB Cal 3
Mem6[Trc3] **S21** dB Mag 1.3 dB / Ref -3 dB

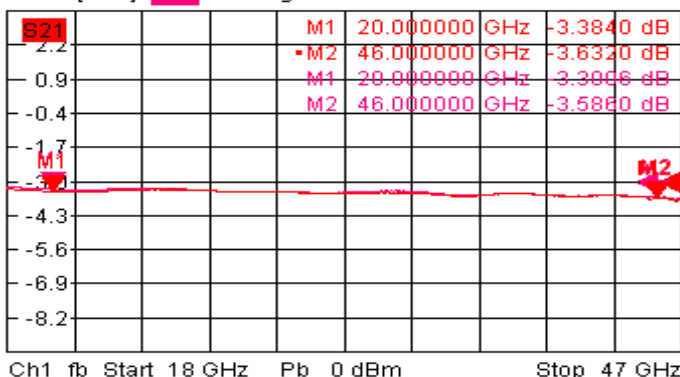

Trc4 **S22** SWR 200 mU/ Ref 1 U Cal 4

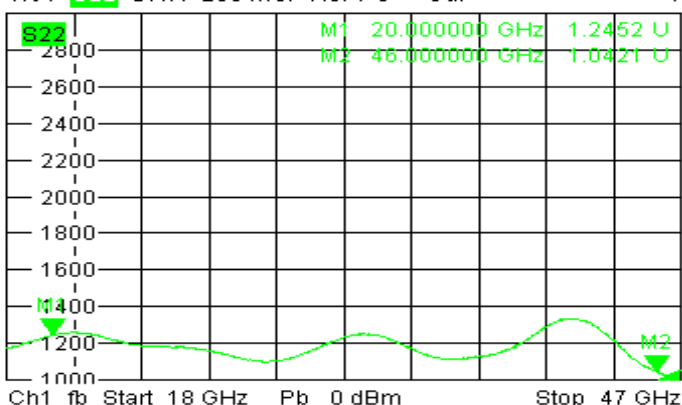

Trc2 **S12** dB Mag 2 dB / Ref -16 dB Cal

2 (Max)

