

Part No: TT2-67-1.85

DC-67GHz, 2W, 1.85mm male Coaxial Fixed Terminations

电气特性 Electrical:

工作频率 Frequency:	DC-67GHz
驻波 VSWR:	1.3 Max
耐功率 Power Handling:	≤2 Watt
阻抗 Impedance:	50 OHMS



机械特性 Mechanical:

操作温度 Operation Temperature:	-55 ~ +125°C
存储温度 Storage Temperature:	-55 ~ +125°C
壳体 Body Material:	Stainless Steel 303
内导体 Center conductor:	Becu, Golden
接口 Connectors:	1.85mm Male
相对湿度 Relative Humidity:	0 ~ 90%

外形尺寸 Outline Drawing:

Unit: mm(inches)

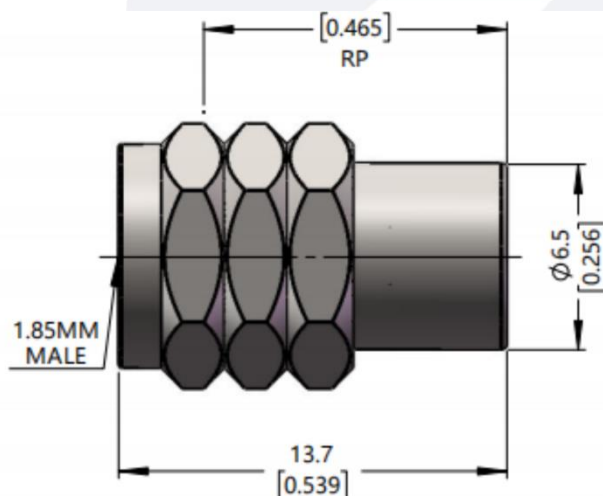

Test Curve:

