

**Model: TLLA4G8G-36-00-Cryo-LP**
**C-band Cryogenic Low Noise Amplifier  
 4-8GHz, NF:2.5K@Temperature≤4K, Gain:40 dB**
**Feature:**

- Ultra Wide Band: 4-8GHz
- Gain: 40dB
- Noise Figure: 2.5K Max@Temperature≤4K
- Technology: InP
- 50 Ohm Matched Input / Output

**电气特性 Electrical:**

参数Parameter	Min.	Typ.	Max.	单位Units
频率范围 Frequency range	4-8			GHz
增益 Gain		40		dB
增益平坦度 Gain Flatness		±1.0		dB
噪声温度 Noise Temperature		3.5		K @Temperature≤15K
噪声温度 Noise Temperature		2.0	2.5	K @Temperature≤4K
输入回波损耗 Input Return Loss			-6	dB
输出回波损耗 Output Return Loss			-13	dB
漏极电压 Drain voltage range		0.6		V DC
漏极电流 Drain current range		20		mA DC
触发电压 Gate voltage range	-2		+2	V DC
功耗 Power Consumption		3.5		mW
阻抗 Impedance	50			Ohms

**机械特性 Mechanical :**

参数Parameter	指标 Value	单位Units
输入输出接口 Input /Output Connector	SMA Female	
直流偏置 Bias	Nano D connector	
尺寸 Size	46*32.5*9	mm
重量 Weight	65	g

**绝对最大值 Absolute Maximum Ratings:**

参数Parameter	指标 Value
漏极电压 Drain voltage range	+1.2V
触发电压 Gate voltage range	±2V
ESD灵敏度 ESD sensitivity (HBm)	Class 0, passed 150V

外形尺寸 Outline Drawing:

Unit: mm

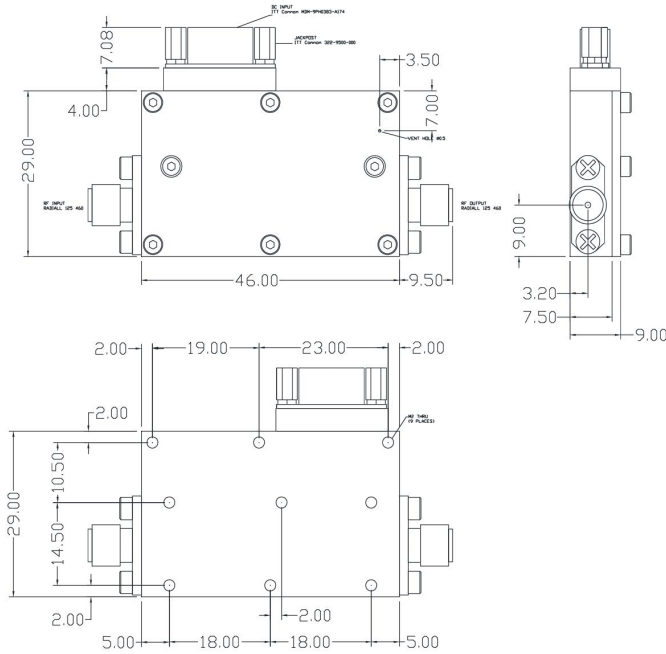

Nano D Female Define	
引脚 Pin #	功能 Function
1	GND
2	VD1 (0.5 to 1.2V)
3	VG1 (-2 to +2V)
4-9	NC



Note: Cryogenic low noise amplifiers made with InP FETs have been found very sensitive to ESD and leakage from the power supplies.

订货信息 Ordering Information:

标准型号 Part Number	描述 Description	版本号 Revision
TLLA4G8G-36-00-Cryo-LP	C-band Cryogenic Low Noise Amplifier 4-8GHz, NF:2.0K@Temperature≤4K, Gain:40 dB, low power	Rev.1.3

典型曲线 Typical Performance Data:

