

Power Amplifier

6-18GHz/24dB Gain/30dBm Psat

Model: TLPA6G18G-24-30

TLPA6G18G-24-30 is a power amplifier with a typical small signal gain of 24 dB and a nominal Psat of 33 dBm across the frequency range of 6 to 18 GHz. The DC power requirement for the amplifier is +8 VDC/0.6 A. The input and output port configuration offers coax adapter structure with SMA female.

Features:

- Frequency range: 6-18GHz
- Gain: 24dB Typ
- Output Power Psat: 30dBm Min
- Good Power and Gain Flatness
- 50 Ohm Matched Input / Output

Applications:

- Cellular
- PCN
- GSM
- ISM
- Lab Test

电气特性 Electrical Characteristics:

参数 Parameter	Min	Typ	Max	单位 Units
频率范围 Frequency range	6		18	GHz
小信号增益 Small Signal Gain		24		dB
增益平坦度 Gain Flatness		±2.5		dB
饱和输出功率 Output Psat	30	33		dBm
输入驻波 Input VSWR		1.8	2.2	:1
输出驻波 Output VSWR		1.8	2.2	:1
直流电压 DC Voltage		8		V DC
直流电流 DC Supply Current		0.6		A
阻抗 Impedance		50		Ohms

机械特性 Mechanical Specifications:

参数 Parameter	指标 Value	单位 Units
输入/输出接口 Input /Output Connector	SMA Female/SMA Female	
直流偏置 DC Bias	Solder Pin	
尺寸 Size	44*52*13	mm
重量 Weight	1000	g

绝对最大值 Absolute Maximum Ratings:

参数 Parameter	指标 Value
供电偏置电压 Supply Bias Voltage	TBD
输入功率 RF Input Power	+10 dBm
ESD灵敏度 ESD sensitivity (HBm)	Class 0, passed 150V

外形图 Outline Drawing:

Unit:mm

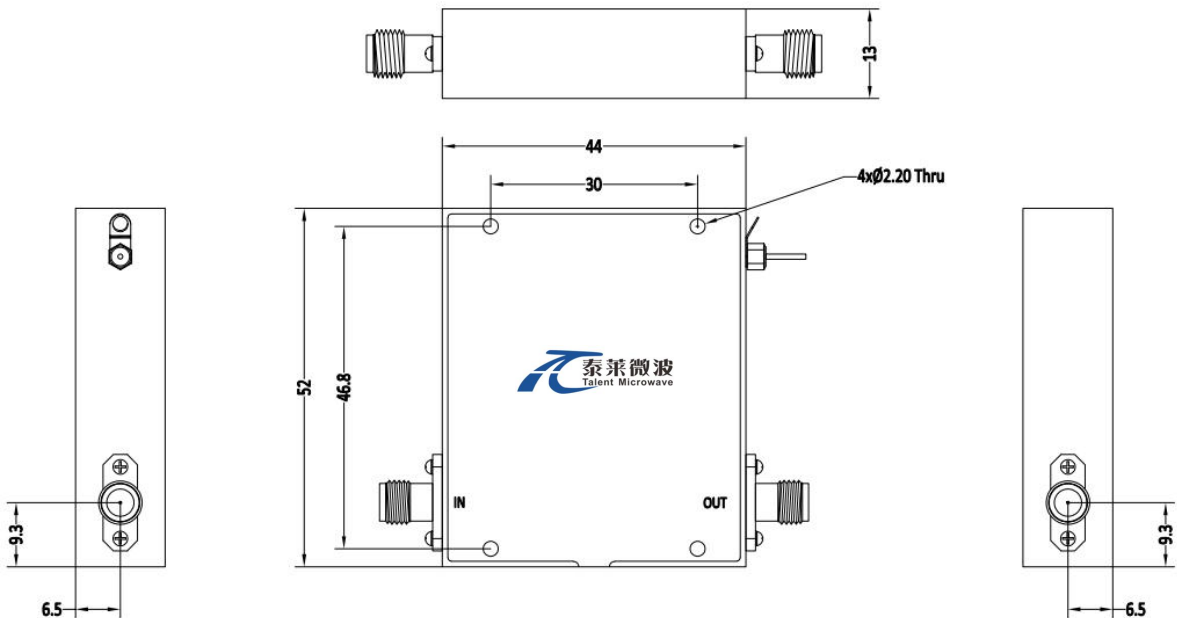

*****Heat Sink Required During Operation**



ESD Protection: Strictly adhere to ESD precautions to prevent electrostatic damage.

温度环境 Environmental Conditions:

参数 Parameter	Min	Typ	Max	单位 Units
操作温度 Operating Temperature*	-40		+60	°C
存储温度 Non-operating Temperature*	-50		+70	°C
相对湿度 Relative humidity		95		%
海拔 Altitude	10,000			feet
震动 Shock / Vibration(MIL-STD-810F)	25g rms (15 degree 2KHz) endurance, 1 hour per axis			
冲击 Shock(non operating)	20G for 11msc half sin wave,3 axis both directions			

*Note: For a wider temperature range, please consult the manufacturer.

订货信息 Ordering Information:

标准型号 Base Number	描述 Description	版本号 Revision
TLPA6G18G-24-30	Power amplifier 6-18GHz, Gain:24dB,Psat:30dBm,+8V DC,Without Heatsink	Rev.1.1
TLPA6G18G-24-30-HS	Power amplifier 6-18GHz, Gain:24dB,Psat:30dBm,+8V DC,With Heatsink	Rev.1.1

典型曲线 Typical Performance Data:

VSWR&Gain vs Frequency

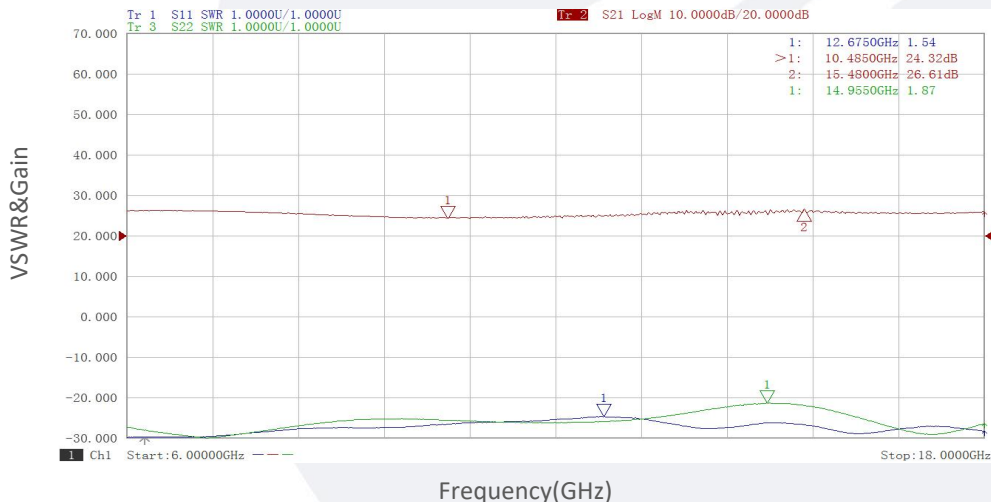

Note: Above data is for ref only, actual data may vary from unit to unit depending on operating environment and other factors like material lots etc.

典型曲线 Typical Performance Data:

Gain vs Output Power

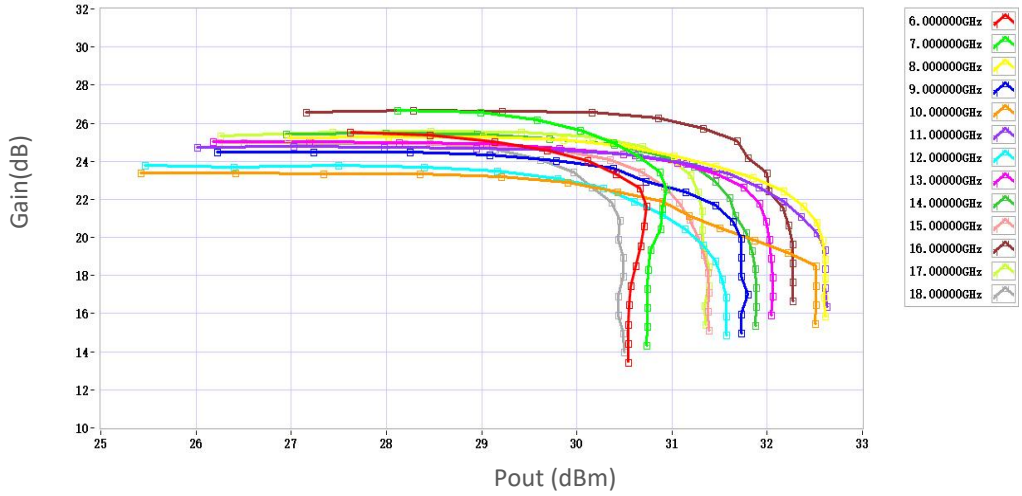

P1dB vs Frequency

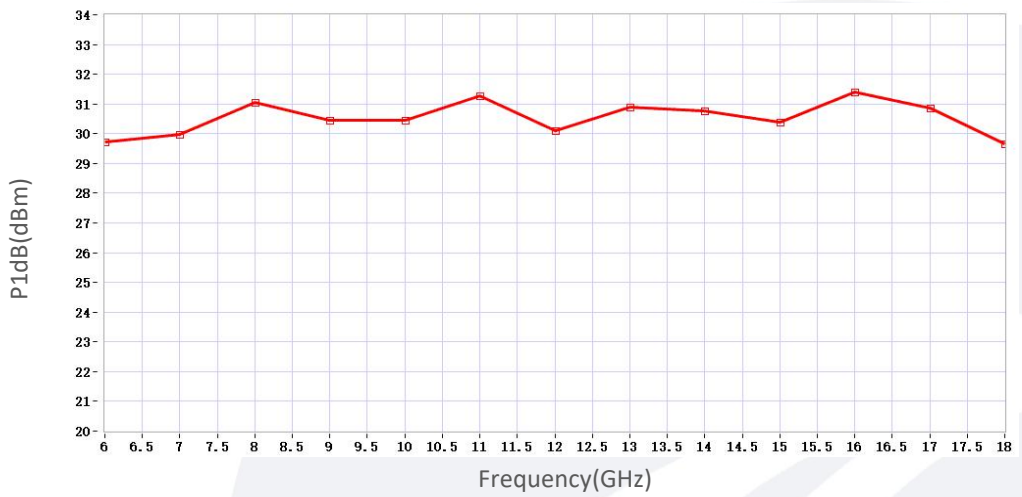

P3dB vs Frequency

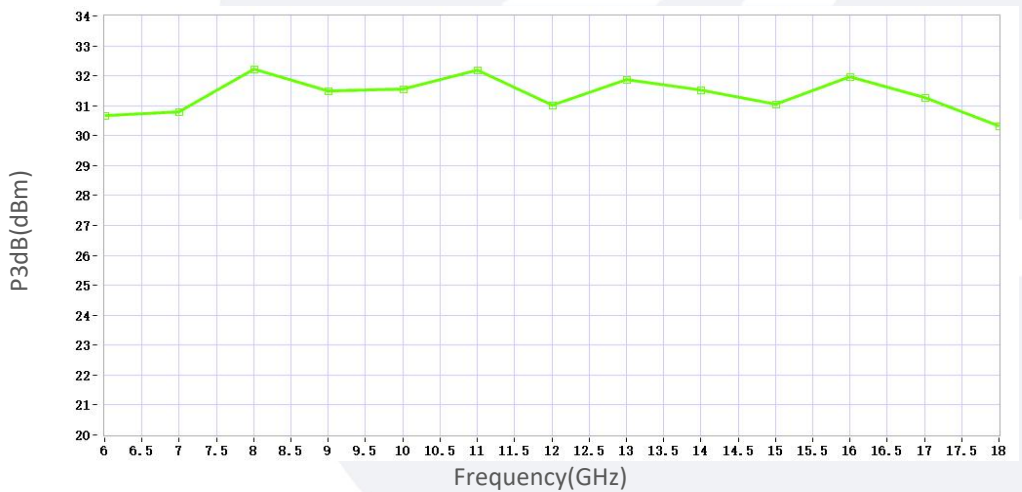

Note: Above data is for ref only, actual data may vary from unit to unit depending on operating environment and other factors like material lots etc.

典型曲线 Typical Performance Data:

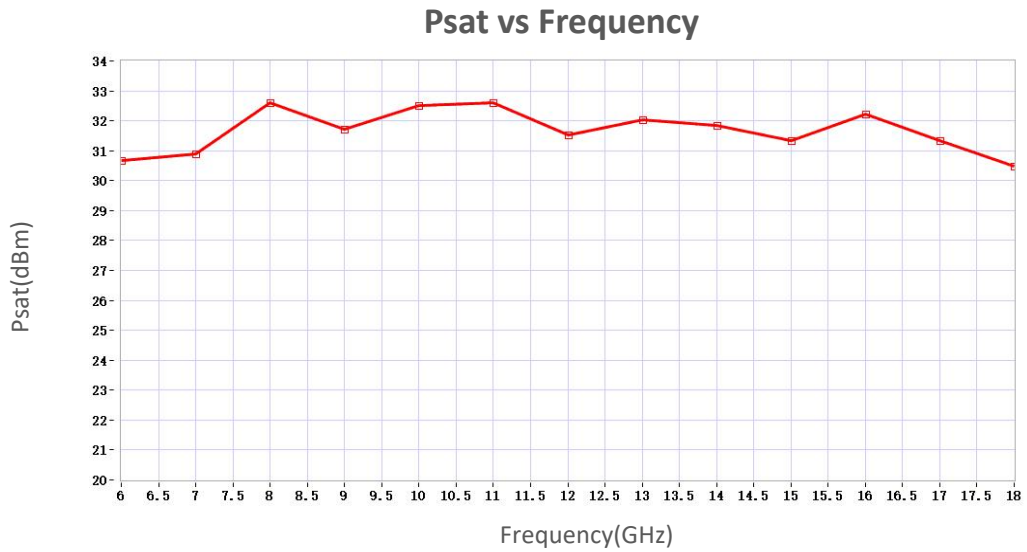

Note: Above data is for ref only, actual data may vary from unit to unit depending on operating environment and other factors like material lots etc.