

IQ Mixer

RF:2-18 GHz/LO:2-18 GHz/IF:DC-3 GHz

Model: TLIQ-0218-03-S

TLIQ-0218-03-S is an ultra-broadband mixer spanning 2 to 18 GHz on the RF and LO ports with an IF from DC to 3 GHz. Up to 20 dBc of image rejection is available due to the excellent phase and amplitude balance of its on-chip LO quadrature hybrid.

Features:

- RF/LO coverage : 2-18 GHz
- IF operation : DC-3 GHz
- Conversion loss: 15dB Typ
- LO power : 15dBm Typ
- Image Rejection : 20dBc Typ

Applications:

- Single Sideband and Image Rejection Mixing
- IQ Modulation / Demodulation
- Vector Amplitude Modulation
- Band Shifting

电气特性 Electrical Characteristics:

参数 Parameter	Min	Typ	Max	单位 Units
RF频率 RF Frequency	2		18	GHz
LO频率 LO Frequency	2		18	GHz
LO驱动功率 LO-Input power	13	15	20	dBm
IF频率 IF Frequency	DC		3	GHz
镜像抑制 Image Rejection @RF/LO:2-18GHz,I+Q:0.091GHz		20		dBc
变频损耗 Conversion Loss @RF/LO:2-18GHz,I/Q:DC-3GHz		15		dB
IF输入1dB压缩点 IF Input P1dB		11		dBm
输入3阶交调截止点 Input IP3 @I/Q= 0.091 GHz		20		dBm
输入3阶交调截止点 Input IP3 @IF = 0.091 GHz		23		dBm
LO to IF 隔离 LO to IF Isolation		23		dB
LO to RF 隔离 LO to RF Isolation		45		dB
RF to IF 隔离 RF to IF Isolation		30		dB

机械特性 Mechanical Specifications:

参数 Parameter	指标 Value	单位 Units
RF接口 RF Connector	SMA Female	
LO接口 LO Connector	SMA Female	
IF接口 IF Connector	SMA Female	
尺寸 Size	17.5*17.5*8.5(Without Connector)	mm

绝对最大值 Absolute Maximum Ratings:

参数 Parameter	指标 Value
LO输入功率 LO Input Power	+20 dBm
RF/IF输入功率 RF/IF Input Power	+20 dBm
ESD灵敏度 ESD sensitivity (HBm)	Class 0, passed 150V

外形图 Outline Drawing:

Unit:mm

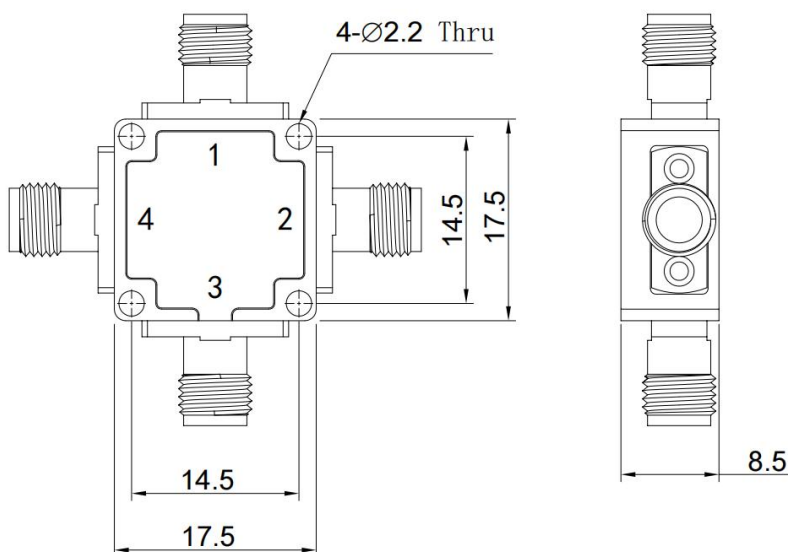

端口 Port	指标 Value
1	LO
2	I
3	Q
4	RF



ESD Protection: Strictly adhere to ESD precautions to prevent electrostatic damage.

温度环境 Environmental Conditions:

参数 Parameter	Min	Typ	Max	单位 Units
操作温度 Operating Temperature	-45		+85	°C
存储温度 Non-operating Temperature	-55		+100	°C
相对湿度 Relative humidity		95		%
海拔 Altitude	10,000			feet
震动 Shock / Vibration(MIL-STD-810F)	25g rms (15 degree 2KHz) endurance, 1 hour per axis			
冲击 Shock(non operating)	20G for 11msc half sin wave,3 axis both directions			

订货信息 Ordering Information:

标准型号 Base Number	描述 Description	版本号 Revision
TLIQ-0218-03-S	Image Rejection or I/Q Mixer RF:2-18GHz,LO:2-18GHz,IF:DC-3GHz	Rev.1.2

典型曲线 Typical Performance Data:

Conversion Loss vs RF Frequency

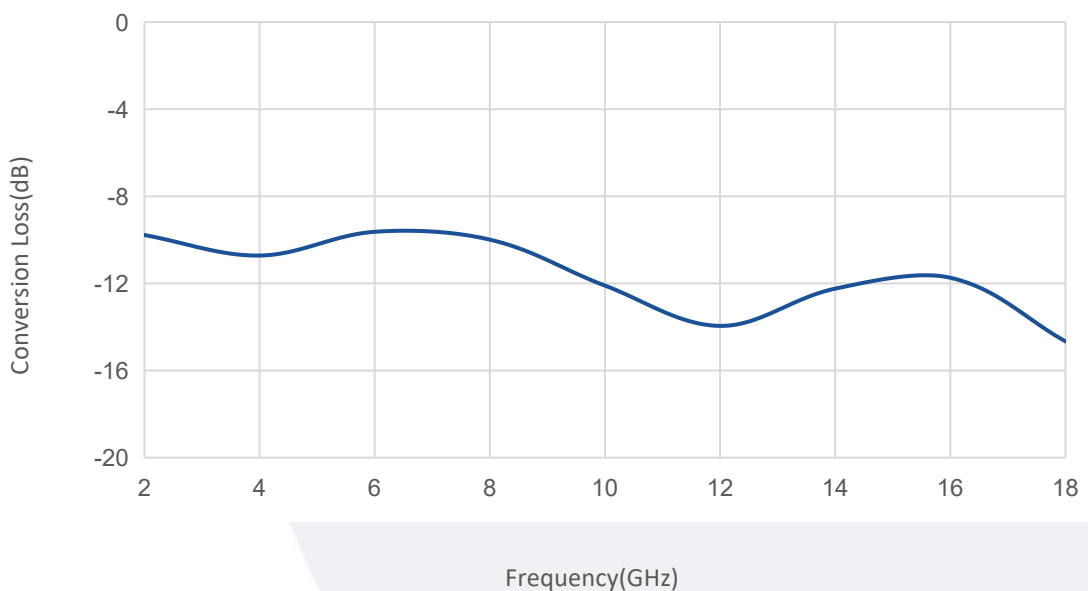

Note: Above data is for ref only, actual data may vary from unit to unit depending on operating environment and other factors like material lots etc.

典型曲线 Typical Performance Data:

Image Rejection vs LO Frequency

I+Q=0.5GHz

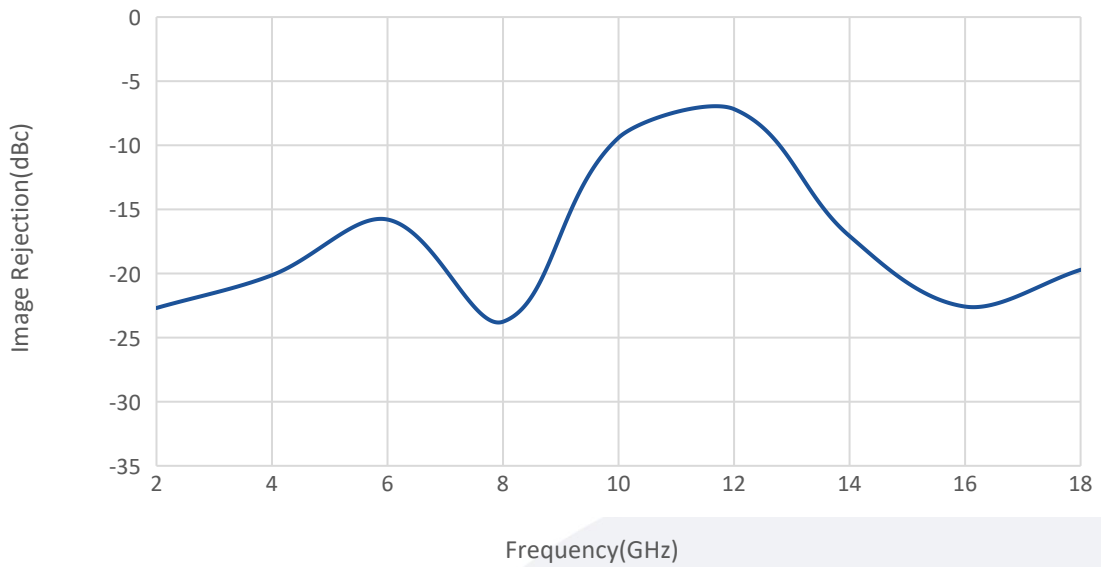

LO to I Isolation vs Frequency

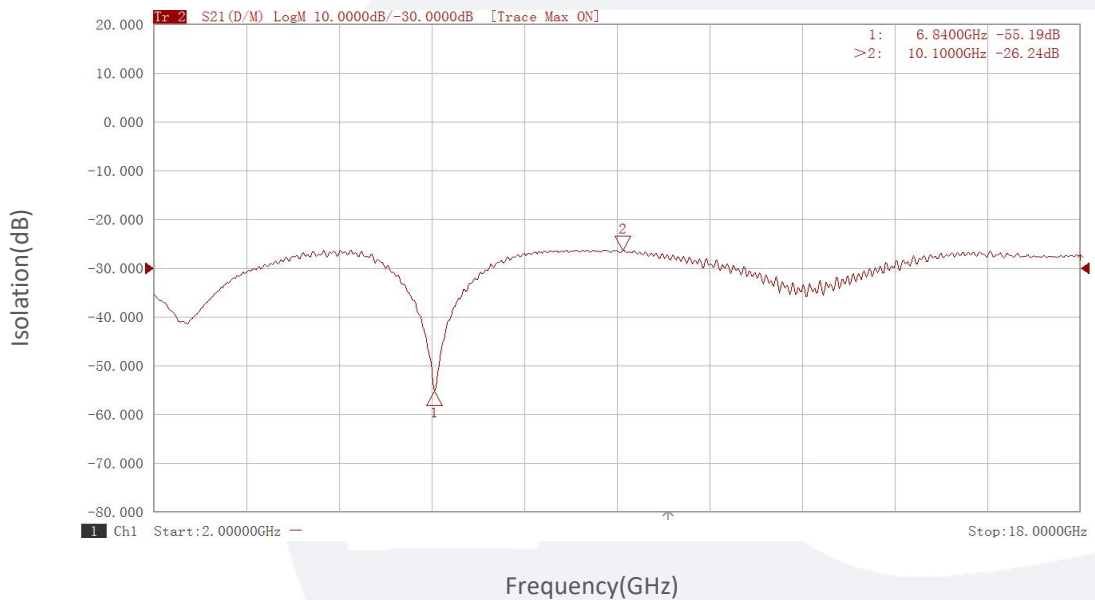

Note: Above data is for ref only, actual data may vary from unit to unit depending on operating environment and other factors like material lots etc.

典型曲线 Typical Performance Data:

LO to Q Isolation vs Frequency

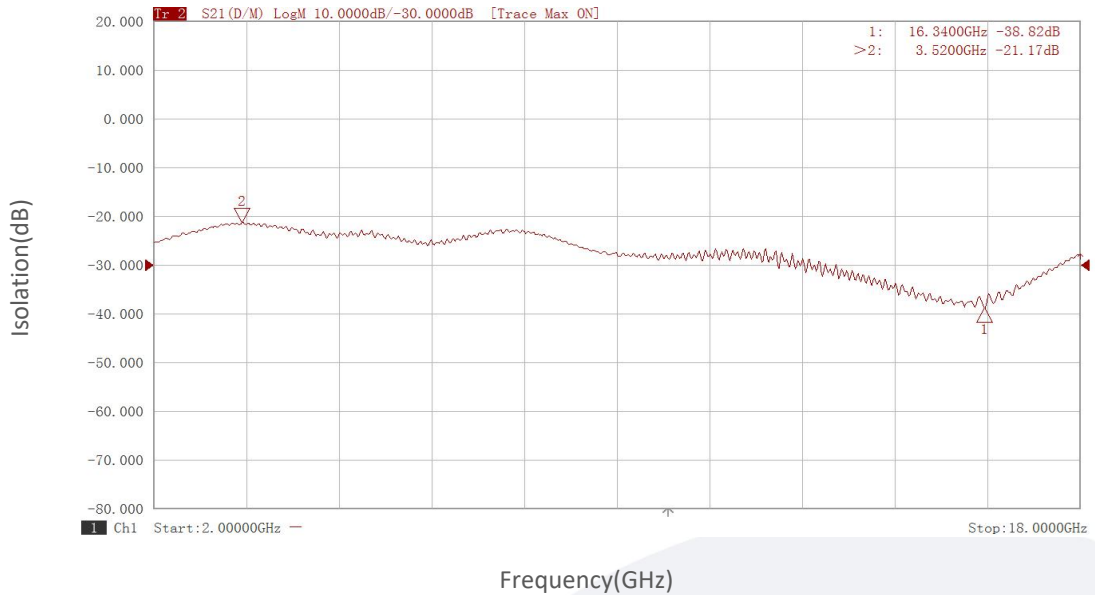

LO to RF Isolation vs Frequency

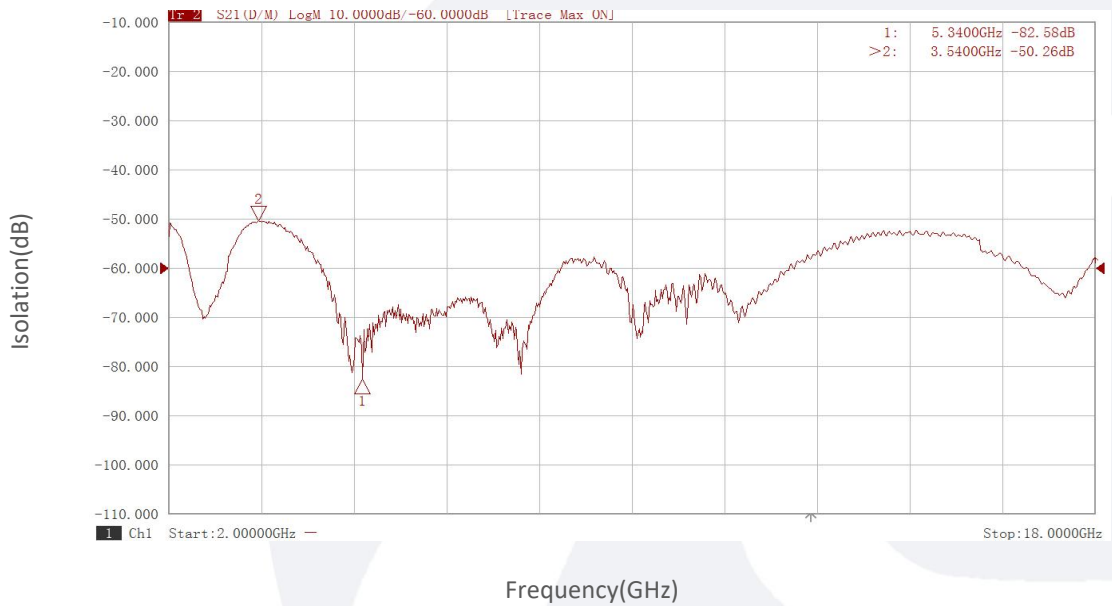

Note: Above data is for ref only, actual data may vary from unit to unit depending on operating environment and other factors like material lots etc.

典型曲线 Typical Performance Data:

RF to I Isolation vs Frequency

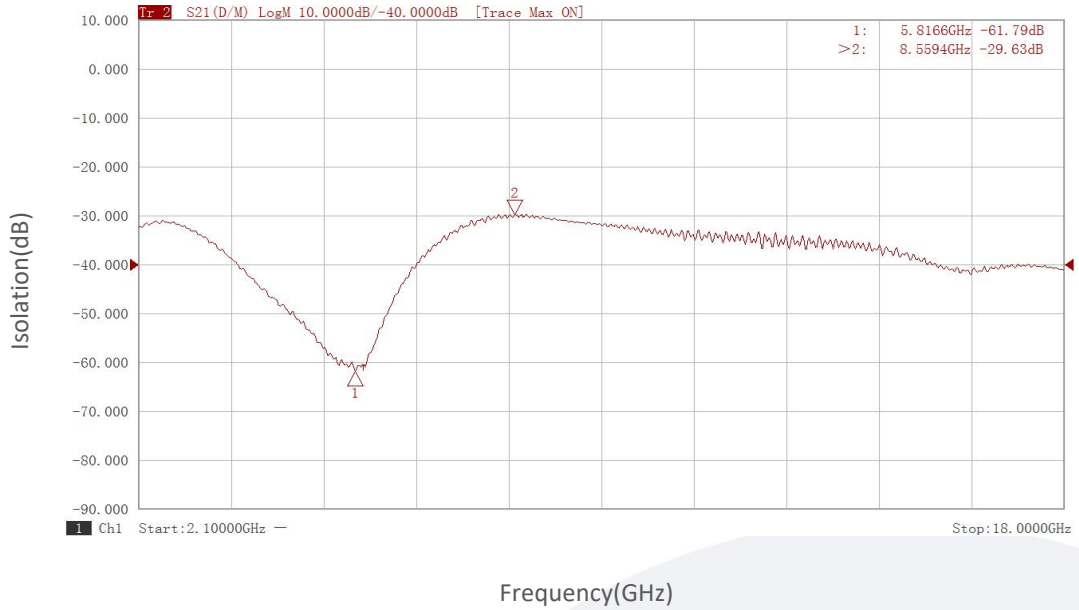

RF to Q Isolation vs Frequency

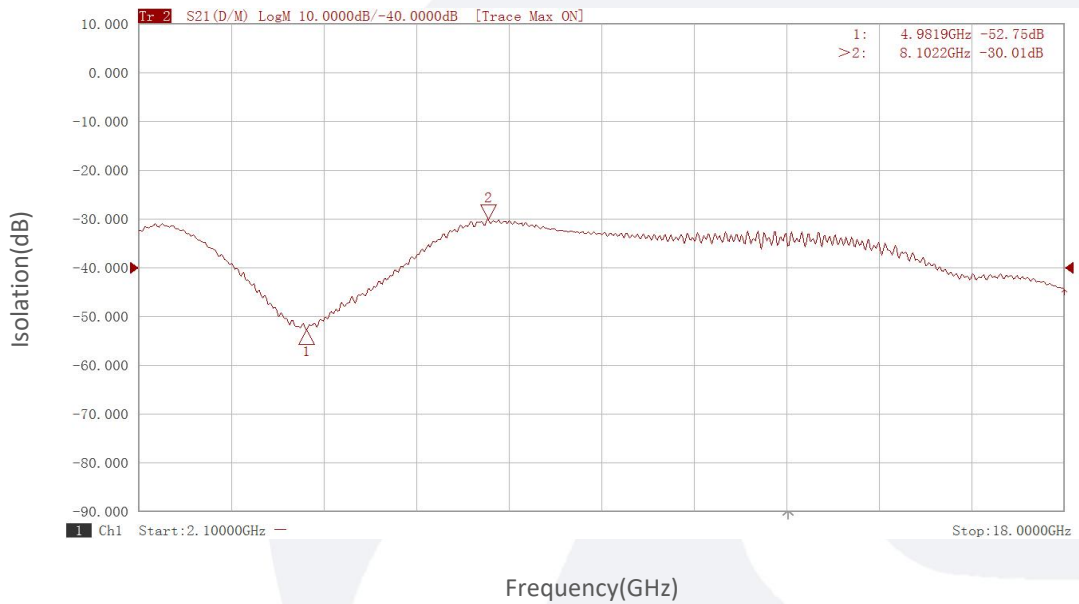

Note: Above data is for ref only, actual data may vary from unit to unit depending on operating environment and other factors like material lots etc.