

Standard Gain Horn Antenna

WR-15/50-75GHz/20dBi Typ, Gain

Model:TL-15HA20

TL-15HA20 is a standard gain horn antenna that operates from 50 GHz to 75 GHz. The antenna offers 20 dBi nominal gain. The input of this antenna is a WR-15 waveguide with UG-385/U anti-cocking flange. The standard gain horn is offered for antenna range calibration purpose mainly, but it can be also used for general purpose system set ups.

Features:

- Operating Frequency 50 to 75 GHz
- Linear Polarization
- Good Impedance Match

Applications:

- Antenna Ranges
- Antenna Gain Measurements
- System Setups

电气特性 Electrical Characteristics:

参数 Parameter	Min	Typ	Max	单位 Units
频率范围 Frequency Range	50		75	GHz
增益 Gain		20		dBi
极化方式 Polarization mode	Linear			
驻波 Input VSWR			1.1	:1

环境和机械特性 Environmental And Physical Characteristics:

类型 Description	参数 Parameter	单位 Units
材质 Material	Brass	
接口 Connectors	WR-15/UG-385/U	
尺寸 Size	47*16.5*21	mm
重量 Weight	30	g

外形图 Outline Drawing:

Unit:mm

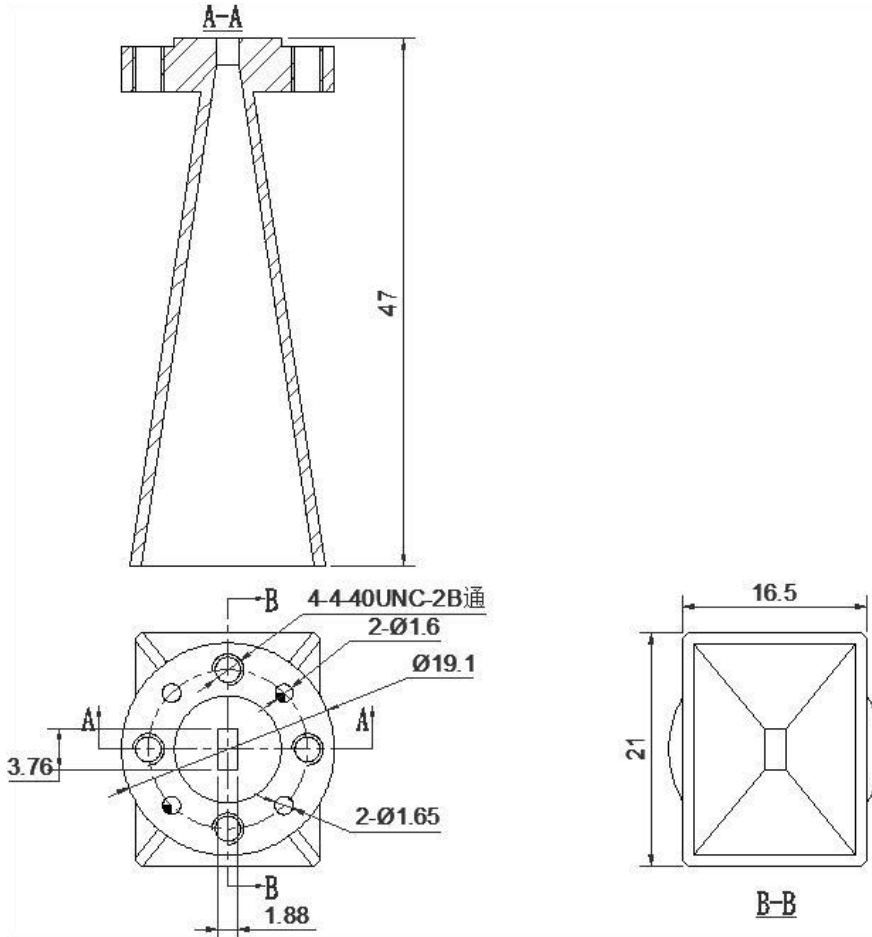

ESD Protection: Strictly adhere to ESD precautions to prevent electrostatic damage.

订货信息 Ordering Information:

标准型号 Base Number	描述 Description	版本号 Revision
TL-15HA20	Standard Gain Horn Antenna, 50-75GHz, Gain: 20dBi Typ.	Rev.1.0

典型曲线 Typical Performance Data:

VSWR vs Frequency

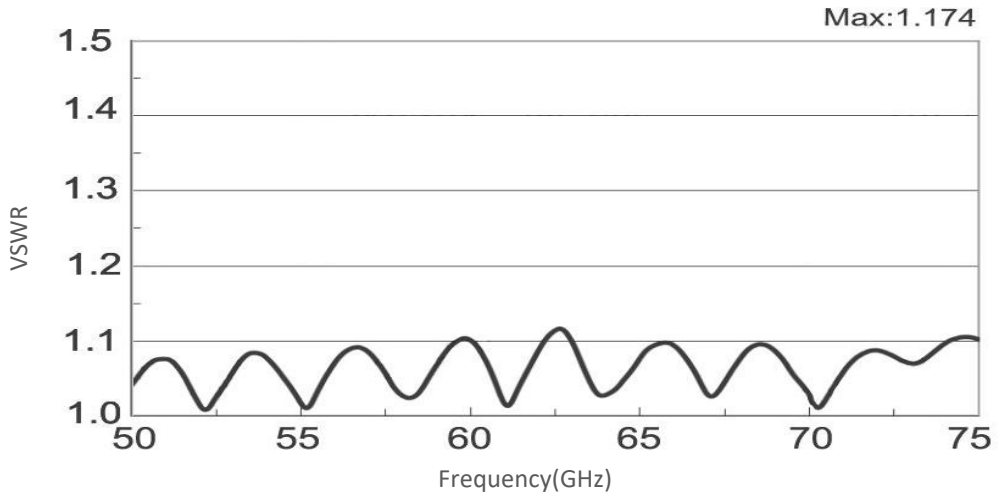

Gain vs Frequency

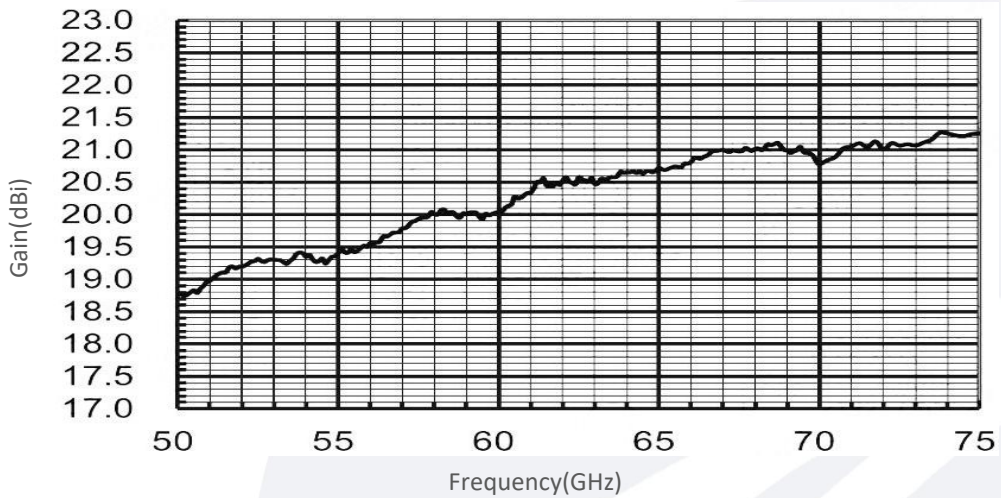

Note: Above data is for ref only, actual data may vary from unit to unit depending on operating environment and other factors like material lots etc.