

Standard Gain Horn Antenna

WR112/6.57-9.99GHz/10dBi Typ, Gain

Model:TL-112SHA10

TL-112SHA10 is a standard gain horn antenna that operates from 6.57 GHz to 9.99 GHz. The antenna offers 10 dBi nominal gain. The input of this antenna is a WR112 waveguide with FBP84 anti-cocking flange. The standard gain horn is offered for antenna range calibration purpose mainly, but it can be also used for general purpose system set ups.

Features:

- Operating Frequency 6.57 to 9.99 GHz
- Gain: 10dBi Typ
- Linear Polarization
- Good Impedance Match

Applications:

- Antenna Ranges
- Antenna Gain Measurements
- System Setups

电气特性 Electrical Characteristics:

参数 Parameter	Min	Typ	Max	单位 Units
频率范围 Frequency Range	6.57		9.99	GHz
增益 Gain		10		dBi
驻波 Input VSWR			1.3	:1

环境和机械特性 Environmental And Physical Characteristics:

类型 Description	参数 Parameter	单位 Units
材质 Material	Aluminum	
表面处理 Finish	Conductive oxidation, spray sea gray paint	
接口 Connectors	WR112/FBP84	
尺寸 Size	47.8*57*70	mm

外形图 Outline Drawing:

Unit:mm

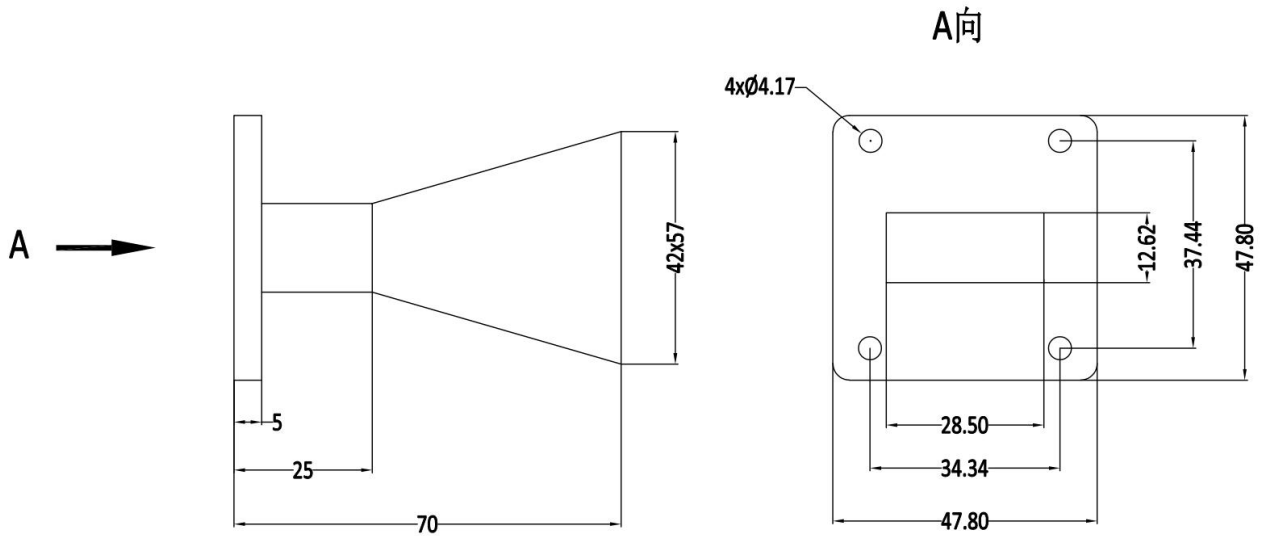

ESD Protection: Strictly adhere to ESD precautions to prevent electrostatic damage.

订货信息 Ordering Information:

标准型号 Base Number	描述 Description	版本号 Revision
TL-112SHA10	Standard Gain Horn Antenna, 6.57-9.99GHz, Gain: 10dBi Typ.	Rev.1.0