

Dual Ridged Horn Antenna

N Female/0.2-2GHz/12dBi Typ, Gain

Model:TL-0220DRHA12N

TL-0220DRHA12N is a dual ridged horn antenna, its operating frequency range from 0.2 GHz to 2 GHz. It provides a nominal gain of 12 dB. At the center frequency, the 3 dB beamwidth on the E plane is 32.8 degrees, and on the H plane is 30.0 degrees. The antenna supports linear polarization. The input port configuration offers coax adapter structure with N female.

Features:

- Operating Frequency 0.2 to 2GHz
- Gain: 12 dBi Min
- Linear Polarization

Applications:

- Radar Systems
- Communication Systems

电气特性 Electrical Characteristics:



参数 Parameter	Min	Typ	Max	单位 Units
频率范围 Frequency Range	0.2		2	GHz
增益 Gain		12		dBi
驻波 Input VSWR			2.5	:1
波束宽度 Beamwidth		E: 32.8; H: 30.0		°
极化方式 Polarization mode		Linear		

机械特性 Physical Characteristics:

类型 Description	参数 Parameter	单位 Units
材质 Material	Aluminium	
表面处理 Finish	True color conductive oxidation, spray paint	
接口 Connectors	N Female	
尺寸 Size	996*946*699	mm

外形图 Outline Drawing:

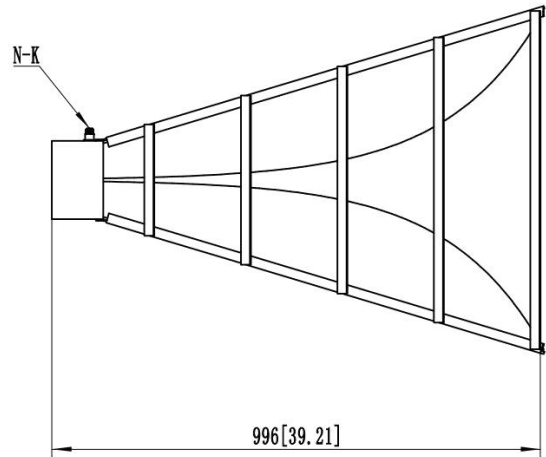
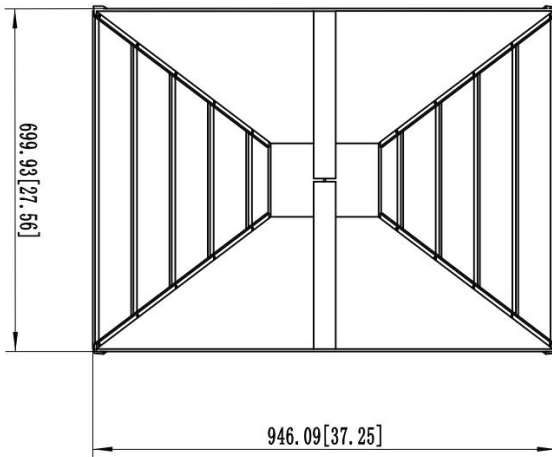
Unit:mm; Tolerance:±0.1mm

ESD Protection: Strictly adhere to ESD precautions to prevent electrostatic damage.

订货信息 Ordering Information:

标准型号 Base Number	描述 Description	版本号 Revision
TL-0220DRHA12N	Dual Ridged Horn Antenna, 0.2-2GHz, Gain: 12 dBi Typ, N Female	Rev.1.0

典型曲线 Typical Performance Data:

VSWR vs Frequency

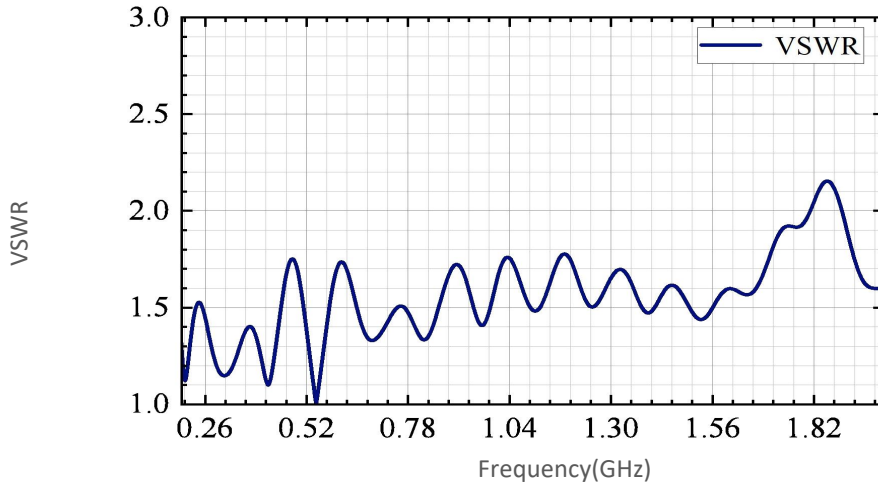

Gain vs Frequency

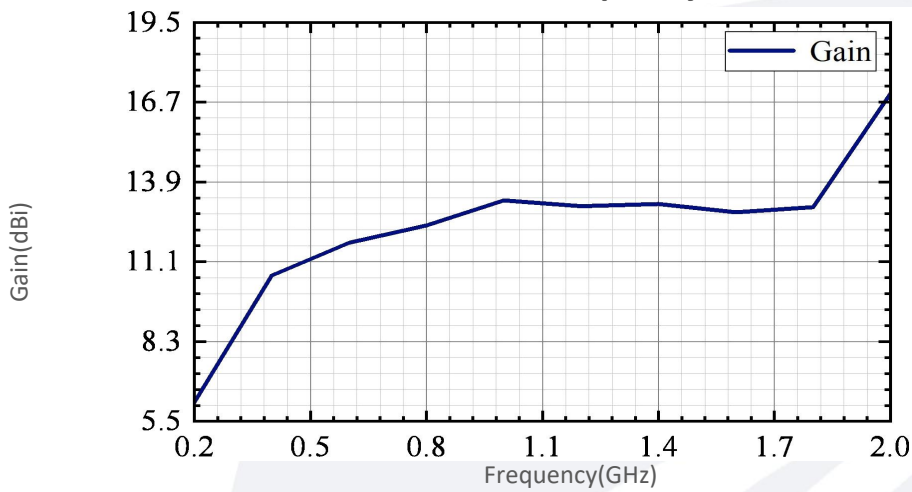

1.1GHz:

Amplitude vs Theta

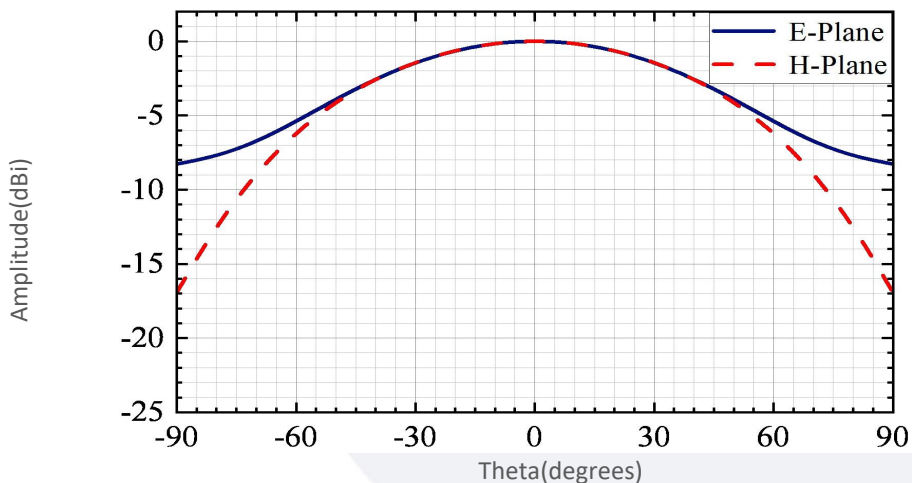

Note: Above data is for ref only, actual data may vary from unit to unit depending on operating environment and other factors like material lots etc.

典型曲线 Typical Performance Data:

1.1GHz:

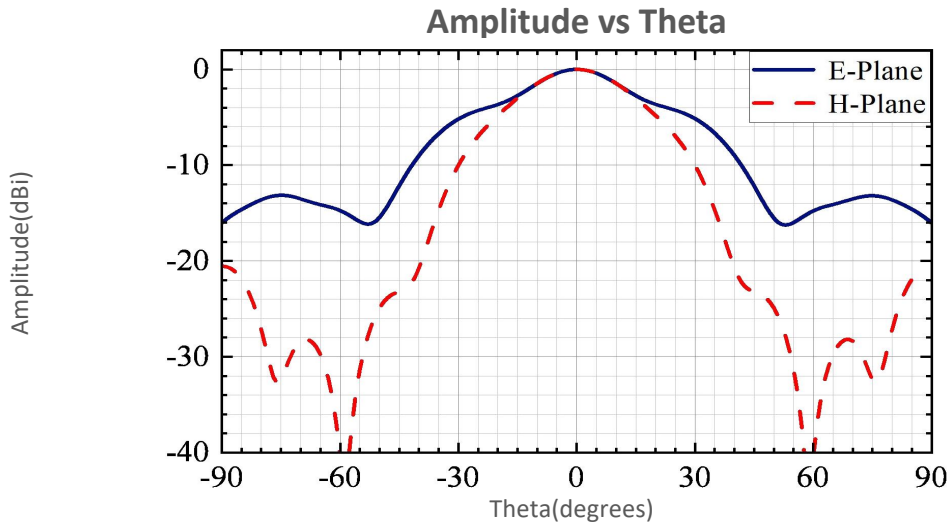

2GHz:

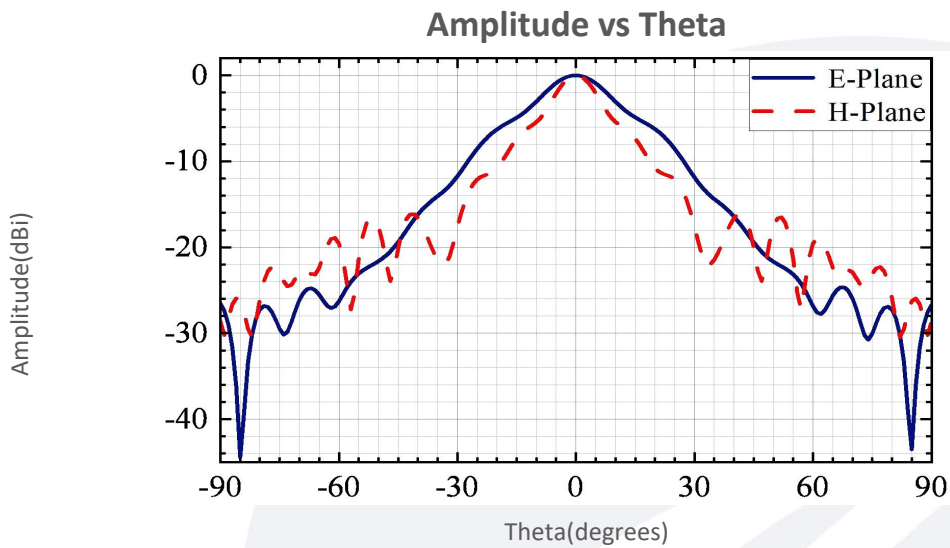

Note: Above data is for ref only, actual data may vary from unit to unit depending on operating environment and other factors like material lots etc.