

Model: TLA18G40G-36-35
Low Noise Amplifier
18-40GHz, NF:3.5dB, Gain:36 dB, P1dB:15dBm
Feature:

- Ultra Wide Band: 18-40GHz
- Gain: 36dB Typ
- Noise Figure: 3.5dB Max
- Good Power and Gain Flatness
- 50 Ohm Matched Input / Output

电气特性 Electrical:

参数Parameter	Min.	Typ.	Max.	单位Units
频率范围 Frequency range	18-40			GHz
增益 Gain		36		dB
增益平坦度 Gain Flatness			±2.5	dB
噪声系数 Noise Figure		3.0	3.5	dB
线性输出功率P1dB		15		dBm
杂散 Non-Harmonic Spurious		-60		dBc
输入驻波 Input VSWR			2.2	:1
输出驻波 Output VSWR			2.2	:1
直流电压 DC Voltage	+8	+12	+20	V DC
直流电流 DC Supply Current		80		mA
阻抗 Impedance	50			Ohms

机械特性 Mechanical :

参数Parameter	指标 Value	单位Units
输入输出接口 Input /Output Connector	2.92 Female	
直流偏置 Bias	Solder Pin	
尺寸 Size	44.8*29.2*11	mm
重量 Weight	55	g



 Available 220V System
 Benchtop Amplifier

绝对最大值 Absolute Maximum Ratings:

参数Parameter	指标 Value
供电偏置电压 Supply Bias Voltage	+20V max
输入功率 RF INPUT POWER	15 dBm max
ESD灵敏度 ESD sensitivity (HBm)	Class 0, passed 150V

外形尺寸 Outline Drawing:

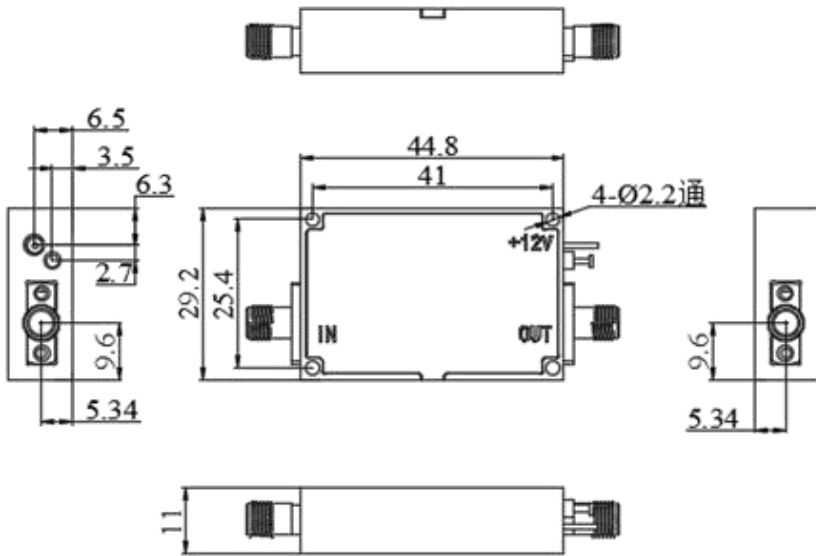
Unit: mm(inches)



OBSERVE PRECAUTIONS
ELECTROSTATIC SENSITIVE
DEVICES

*****Heat Sink Required During Operation**

温度环境 Environmental Conditions:

参数Parameter	Min.	Typ.	Max.	单位Units
操作温度 Operating Temperature	-45		+85	°C
存储温度 Non-operating Temperature	-55		+125	°C
相对湿度 Relative humidity		95		%
海拔 Altitude	50,000			feet
震动 Shock / Vibration(MIL-STD-810F)	25g rms (15 degree 2KHz) endurance, 1 hour per axis			
冲击 Shock(non operating)	20G for 11msc half sin wave,3 axis both directions			

订货信息 Ordering Information:

标准型号 Part Number	描述 Description	版本号Revision
TLLA18G40G-36-35	Low Noise Amplifier, 18-40GHz, Noise Figure:3.5 dB, Gain:36 dB,P1dB:15dBm,20V DC,Without Heatsink	Rev.1.1
TLLA18G40G-36-35-HS	Low Noise Amplifier, 18-40GHz, Noise Figure:3.5 dB, Gain:36 dB,P1dB:15dBm,20V DC,With Heatsink	Rev.1.1

典型曲线 Typical Performance Data:

Gain & VSWR vs Frequency

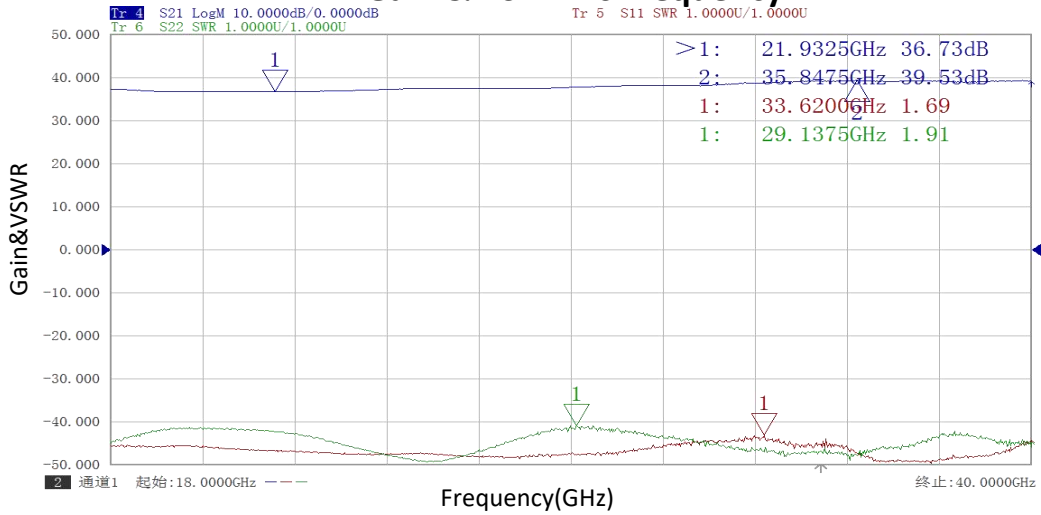

Gain vs Output Power

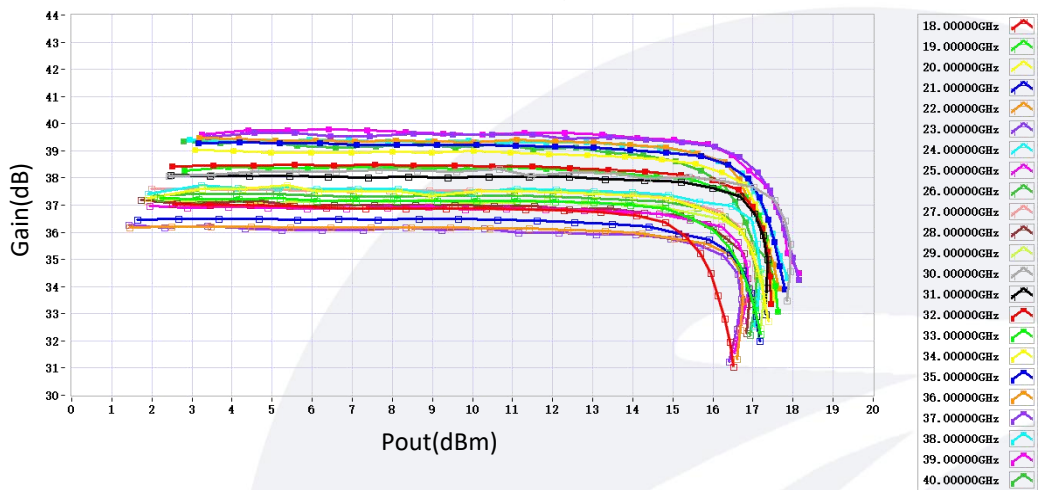

Noise Figure vs Frequency

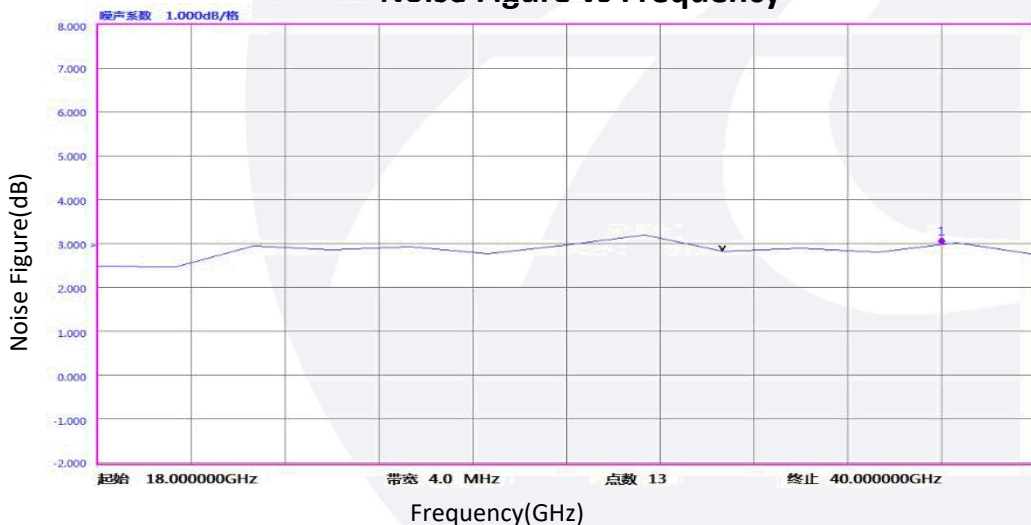

典型曲线 Typical Performance Data:

P1dB vs Frequency

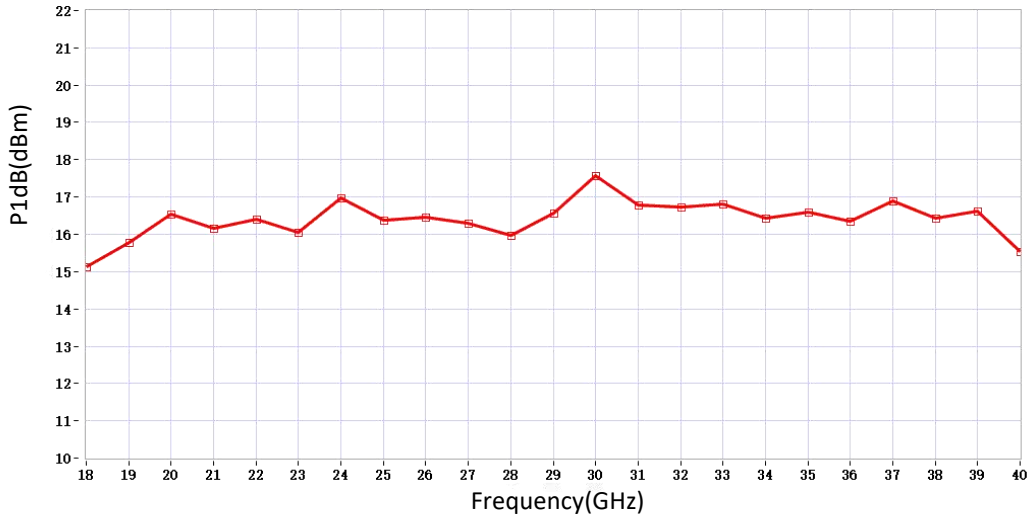

P3dB vs Frequency

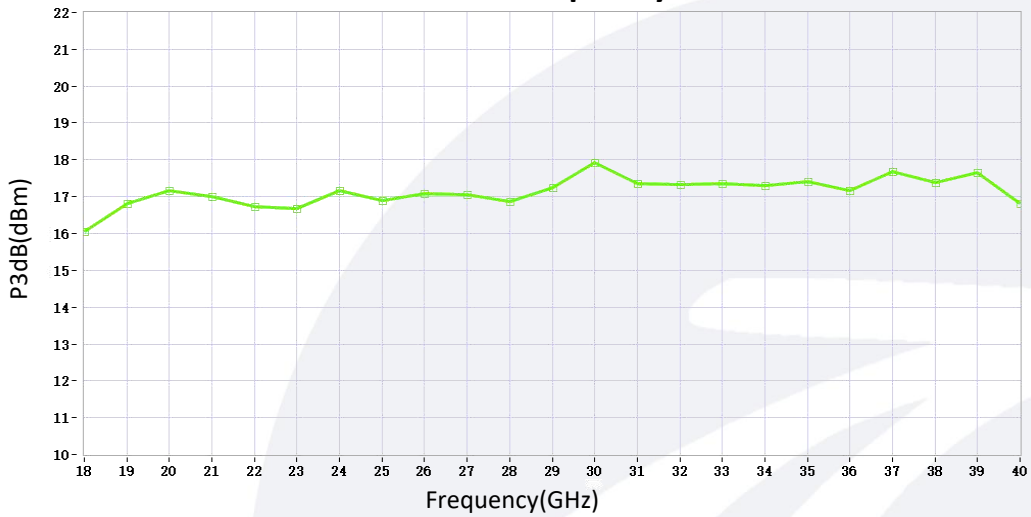

Current vs Output Power

