

Model: TMLA-075110-4240-10
Low Noise Amplifier
75-110GHz, NF:4.0 dB, Gain:42 dB
Feature:

- Ultra Wide Band: 75-110 GHz
- Gain: 42dB Typ
- Noise Figure:4.0dB Typ
- Unconditional stability

电气特性 Electrical Specifications:

参数Parameter	Min	Typ	Max	单位Units
频率范围 Frequency range	75		110	GHz
增益 Gain		42		dB
噪声系数 Noise Figure		4.0		dB
输出功率1dB压缩点 Output P1dB		0		dBm
输入驻波 Input VSWR		2.5		:1
输出驻波 Output VSWR		2.2		:1
直流电压 DC Voltage		+12		V DC
直流供电 DC power supply		80		mA

机械特性 Mechanical Specifications:

参数Parameter	指标 Value	单位Units
输入接口 Input Connector	WR-10/ UG-387/U	
输出接口 Output Connector	WR-10/ UG-387/U	
供电引脚 Power Supply Pin	Solder Pin	
尺寸 Size	39*30*23	mm

绝对最大值 Absolute Maximum Ratings:

参数Parameter	指标 Value
供电偏置电压 Supply Bias Voltage	+13 V
输入功率 RF Input Power	0dBm
ESD灵敏度 ESD sensitivity (HBm)	Class 0, passed 150V

**Available 220V System
 Benchtop Amplifier**

外形尺寸 Outline Drawing:

Unit: mm

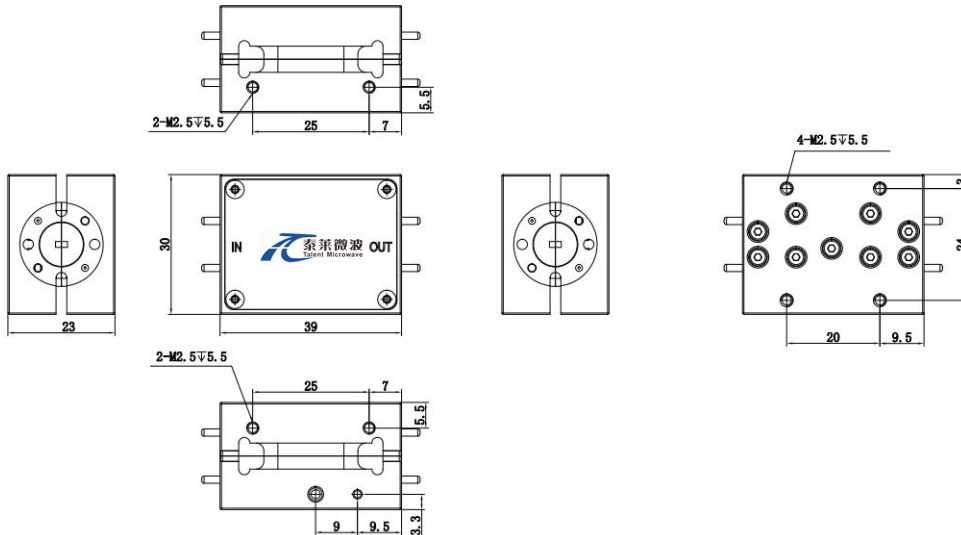

温度环境 Environmental Conditions:



OBSERVE PRECAUTIONS
ELECTROSTATIC SENSITIVE
DEVICES

参数Parameter	Min	Typ	Max	单位Units
操作温度 Operating Temperature	-10		+65	°C
存储温度 Non-operating Temperature	-25		+75	°C
相对湿度 Relative humidity		95		%
海拔 Altitude	50,000			feet
震动 Shock / Vibration(MIL-STD-810F)	25g rms (15 degree 2KHz) endurance, 1 hour per axis			
冲击 Shock(non operating)	20G for 11msc half sin wave,3 axis both directions			

订货信息 Ordering Information:

标准型号 Part Number	描述 Description	版本号Revision
TMLA-075110-4240-10	Low Noise Amplifier,75-110GHz, Noise Figure:4.0dB, Gain:42dB,+12V DC,WR-10	Rev.1.1

典型曲线 Typical Performance Data:

Gain vs Frequency

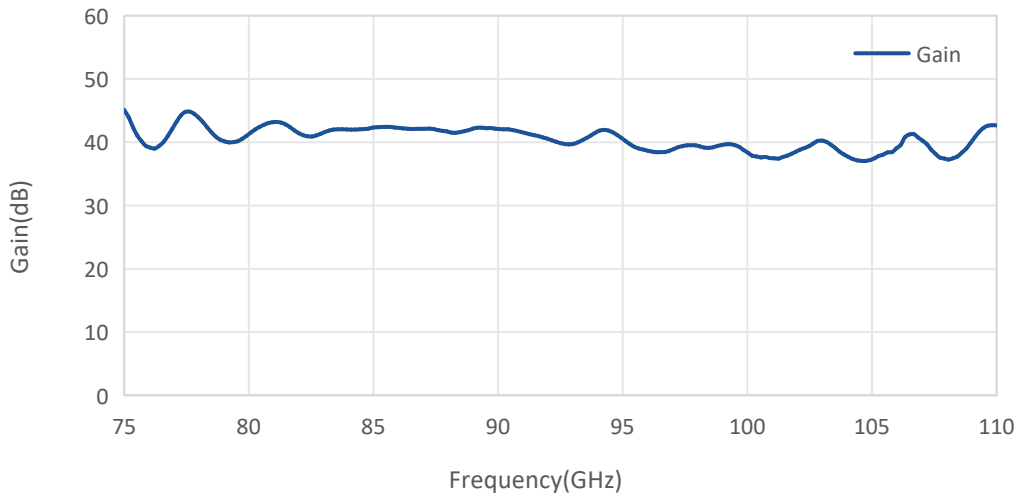

Noise Figure vs Frequency

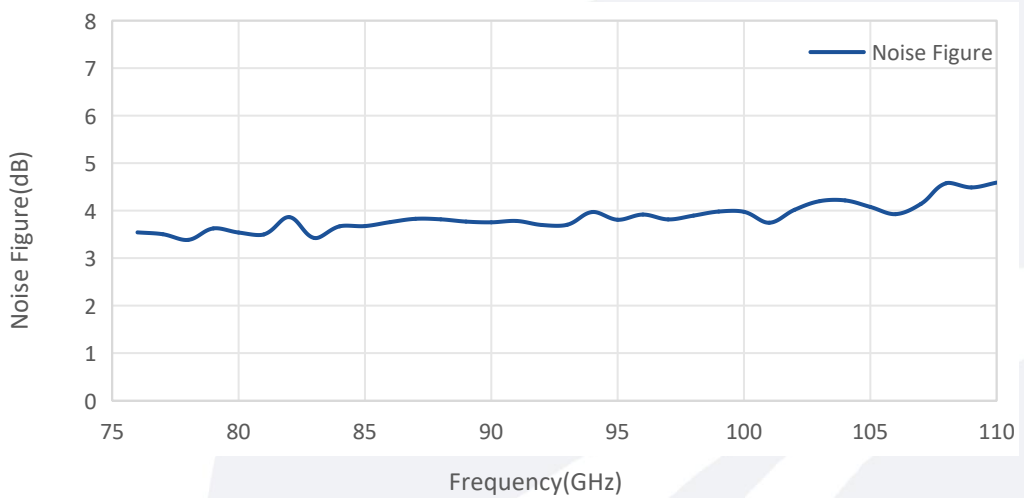

VSWR vs Frequency

