

Solid State High Power Amplifier Systems

74-110GHz/37dB Gain/37dBm Psat/220V AC

Model: TLPA74G110G-37-37-BC

TLPA74G110G-37-37-BC is a solid state high power amplifier systems provides high output power and high gain across the 74 to 110GHz frequency range. The amplifier features a built-in 220V power supply, making it easy to use in most lab environments. This model features thermal self protection, preventing damage to the amplifier and providing added reliability.

Features:

- Frequency range: 74-110GHz
- Gain: 37dB Min
- Psat Output Power: 37dBm Min
- Protection: Over TEM, over voltage, over current, over VSWR protection
- 50 Ohm Matched Input / Output

电气特性 Electrical Characteristics:

参数 Parameter	代码 Symbol	Min	Typ	Max	单位 Units
频率范围 Frequency range	BW	74		110	GHz
工作模式 Working Mode	MOD	CW/PULSE compatible			
功率增益 Power Gain@Psat	GP	37			dB
饱和输出功率 Output Psat	Psat	37			dBm
杂散 Spurious@Psat	Spur		-50		dBc
交流电压 AC Voltage	Vac		220		V AC
功耗 Power Consumption	Pdiss			400	W
阻抗 Impedance	I/O-IMP	50			Ohms

机械特性 Mechanical Specifications:

参数 Parameter	指标 Value	单位 Units
输入/输出接口 Input /Output Connector	WR10/WR10	
供电接口 Power Supply Connector	Y50DX-1203	
尺寸 Size	295*230*132	mm
重量 Weight	≤10	Kg

绝对最大值 Absolute Maximum Ratings:

参数 Parameter	指标 Value
输入功率 RF Input Power	+5 dBm
ESD灵敏度 ESD sensitivity (HBm)	Class 0, passed 150V

外形图 Outline Drawing:

Unit:mm

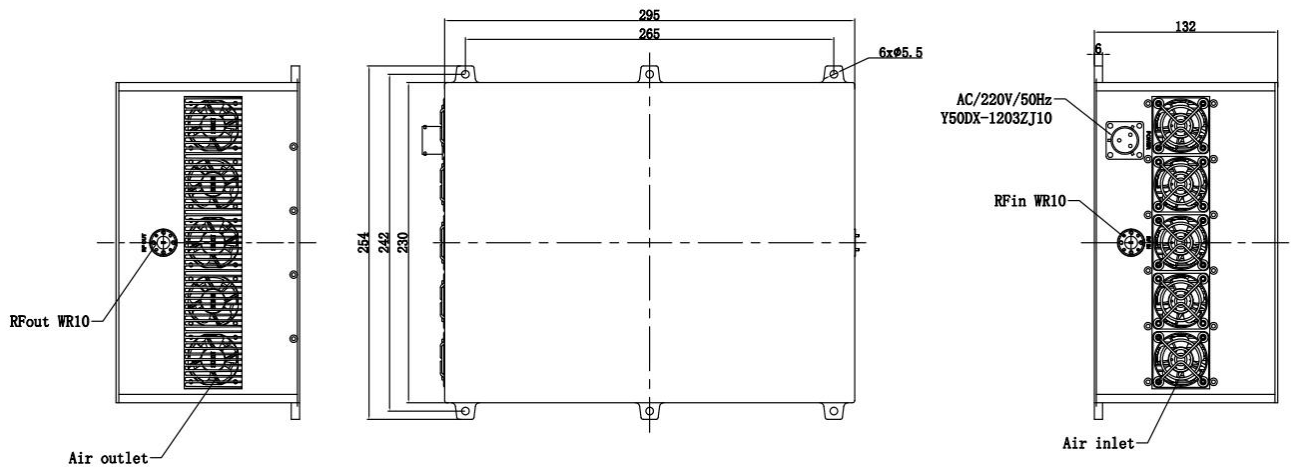

主要功能 Key Features:

参数 Parameter	特点 Advantages
控制功能 Control functions	1, Power setting on/off
内置保护功能 Protection functions	1, Over TEM 2, Over voltage 3, Over current 4, Over VSWR
冷却系统 Cooling system	Built in Cooling system, forced air cooling

温度环境 Environmental Conditions:

参数 Parameter	Min	Typ	Max	单位 Units
操作温度 Operating Temperature*	-20		+50	°C
存储温度 Non-operating Temperature*	-30		+60	°C
相对湿度 Relative humidity		95		%
海拔 Altitude	10,000			feet
震动 Shock / Vibration(MIL-STD-810F)	25g rms (15 degree 2KHz) endurance, 1 hour per axis			
冲击 Shock(non operating)	20G for 11msc half sin wave,3 axis both directions			

*Note: For a wider temperature range, please consult the manufacturer.

订货信息 Ordering Information:

标准型号 Base Number	描述 Description	版本号 Revision
TLPA74G110G-37-37-BC	Solid State High Power Amplifier Systems 74-110GHz, Gain:37dB, Psat:37dBm, 220V AC, Built in Fan Cooling	Rev.1.0