

Power Amplifier

40-50GHz/38dB Gain/38dBm Psat

Model: TLPA40G50G-38-38

TLPA40G50G-38-38 is a power amplifier with a minimum power gain of 38 dB and a nominal Psat of 38 dBm across the frequency range of 40 to 50 GHz. The DC power requirement for the amplifier is +20 VDC/3.5 A. The input and output port configuration offers coax adapter structure with 2.4mm female.

Features:

- Frequency range: 40-50GHz
- Gain: 38dB Min
- Output Power Psat: 38dBm Typ
- Good Power and Gain Flatness
- 50 Ohm Matched Input / Output

Applications:

- Cellular
- PCN
- GSM
- ISM
- Lab Test

电气特性 Electrical Characteristics:

参数 Parameter	Min	Typ	Max	单位 Units
频率范围 Frequency range	40		50	GHz
功率增益 Power Gain	38			dB
饱和输出功率 Output Psat		38		dBm
杂散 Spurious@Pout=38dBm			-50	dBc
直流电压 DC Voltage		+20	+21	V DC
直流电流 DC Supply Current		3.5		A
阻抗 Impedance		50		Ohms

机械特性 Mechanical Specifications:

参数 Parameter	指标 Value	单位 Units
输入/输出接口 Input /Output Connector	2.4mm Female/2.4mm Female	
直流偏置 DC Bias	Feedthru capacitors	

机械特性 Mechanical Specifications:

参数 Parameter	指标 Value	单位 Units
尺寸 Size	60*60*11(Without heatsink) 188*125*146(With heatsink)	mm
重量 Weight	≤300	g

绝对最大值 Absolute Maximum Ratings:

参数 Parameter	指标 Value
供电偏置电压 Supply Bias Voltage	+21 V
输入功率 RF Input Power	+5 dBm
ESD灵敏度 ESD sensitivity (HBm)	Class 0, passed 150V



外形图 Outline Drawing:

Unit:mm

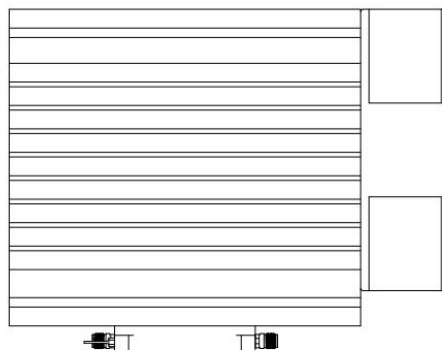
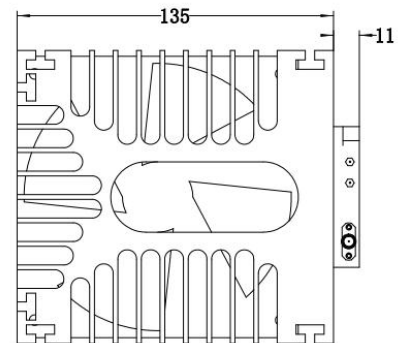
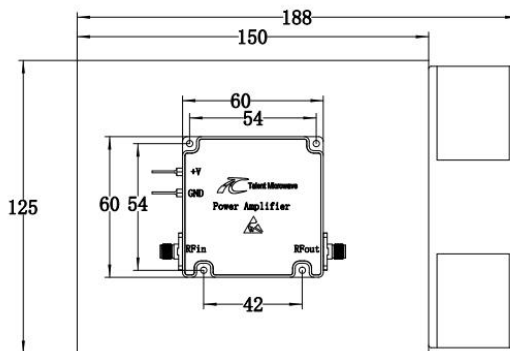

ESD Protection: Strictly adhere to ESD precautions to prevent electrostatic damage.

温度环境 Environmental Conditions:

参数 Parameter	Min	Typ	Max	单位 Units
操作温度 Operating Temperature*	-40		+60	°C
存储温度 Non-operating Temperature*	-50		+70	°C
相对湿度 Relative humidity		95		%
海拔 Altitude	10,000			feet
震动 Shock / Vibration(MIL-STD-810F)	25g rms (15 degree 2KHz) endurance, 1 hour per axis			
冲击 Shock(non operating)	20G for 11msc half sin wave,3 axis both directions			

*Note: For a wider temperature range, please consult the manufacturer.

订货信息 Ordering Information:

标准型号 Base Number	描述 Description	版本号 Revision
TLPA40G50G-38-38	Power amplifier 40-50GHz, Gain:38dB,Psat:38dBm,+20V DC,With Heatsink	Rev.1.1

典型曲线 Typical Performance Data:

Input VSWR vs Frequency

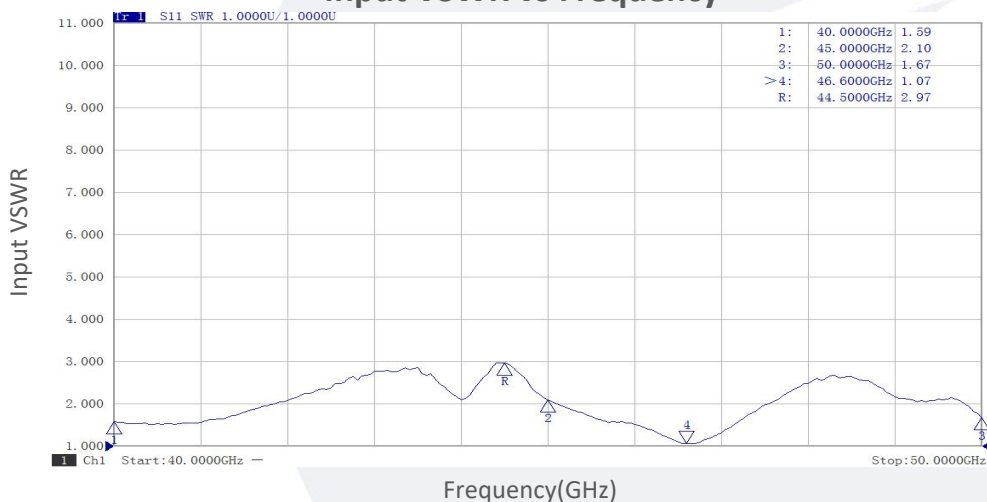

Note: Above data is for ref only, actual data may vary from unit to unit depending on operating environment and other factors like material lots etc.

典型曲线 Typical Performance Data:

Small Signal Gain vs Frequency

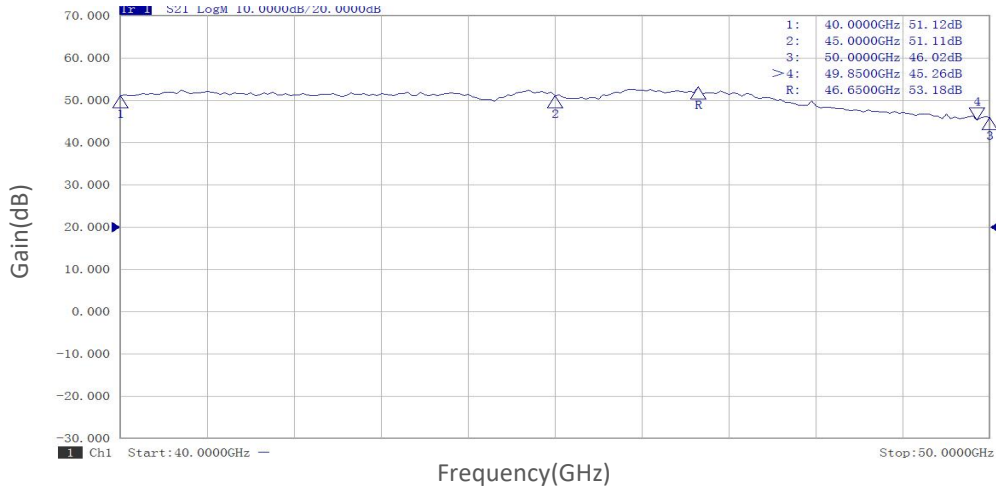

Pout@Equal-Pin

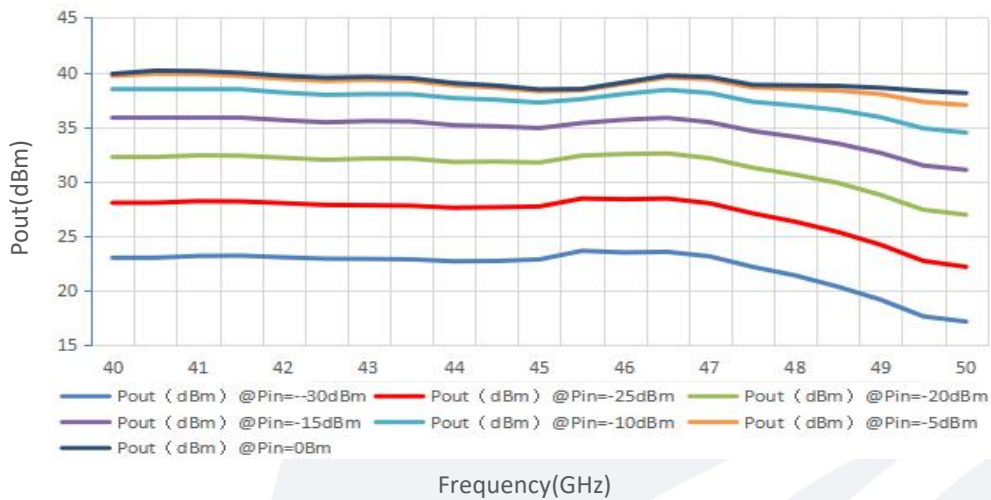

Pin@Equal-Pout

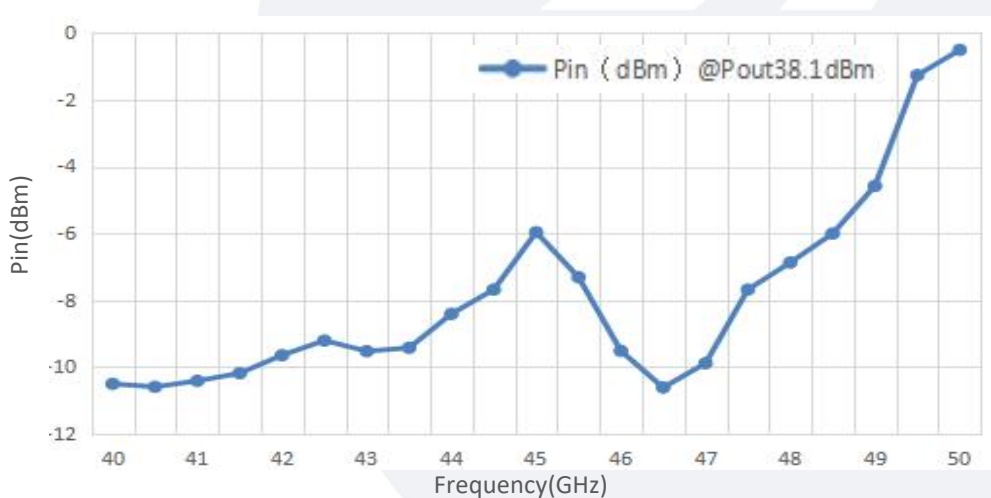

Note: Above data is for ref only, actual data may vary from unit to unit depending on operating environment and other factors like material lots etc.

典型曲线 Typical Performance Data:

Pout@Pin

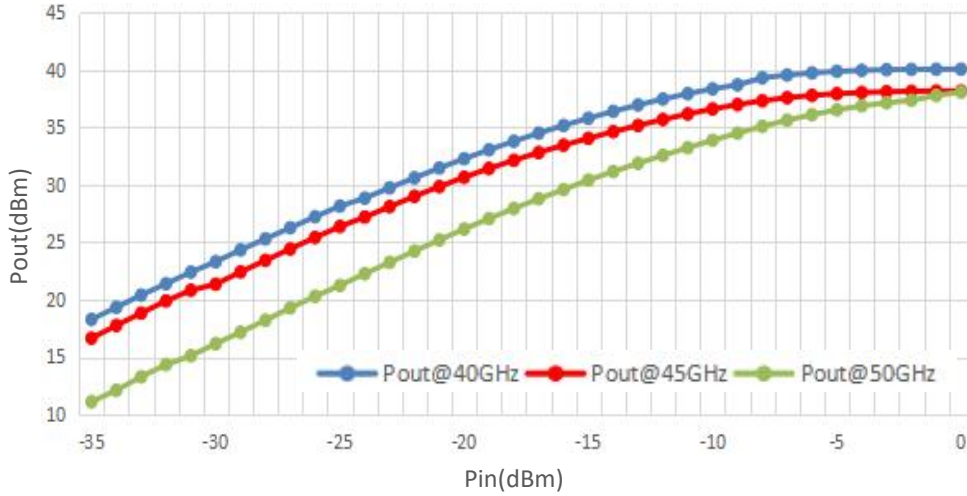

P1dB VS Frequency

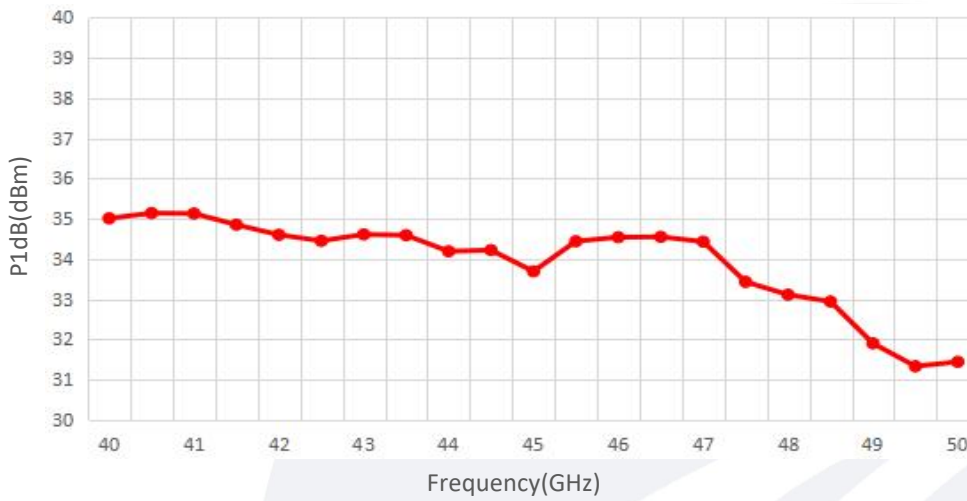

Spurious vs Frequency

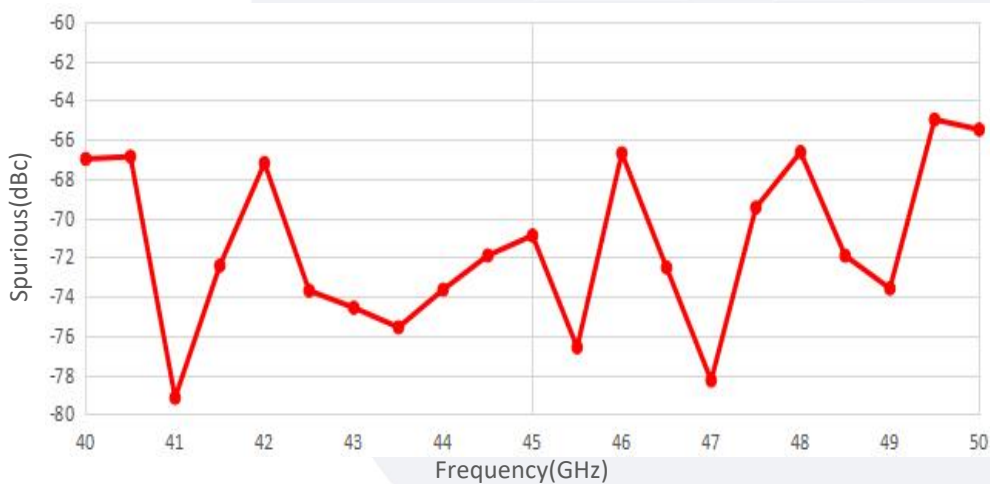

Note: Above data is for ref only, actual data may vary from unit to unit depending on operating environment and other factors like material lots etc.

典型曲线 Typical Performance Data:

Power dissipation

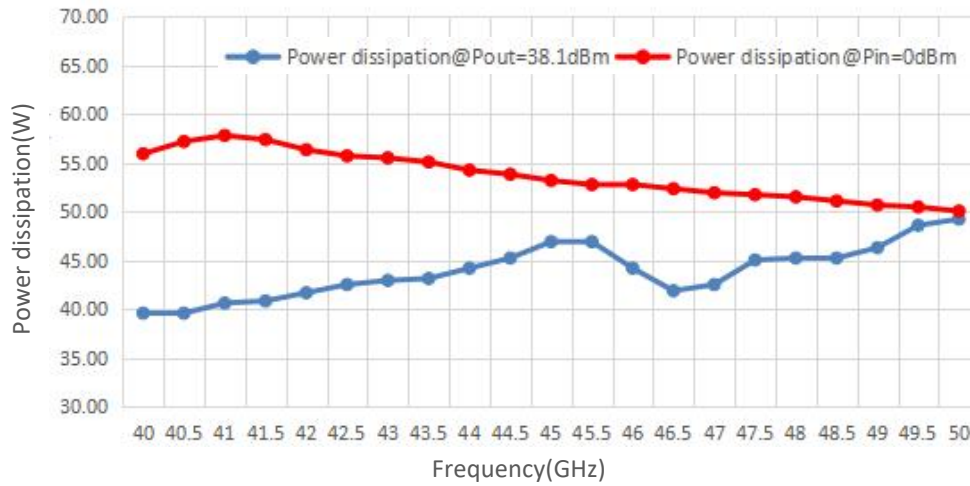

Note: Above data is for ref only, actual data may vary from unit to unit depending on operating environment and other factors like material lots etc.